

Service Manual

Trimmer TR 85

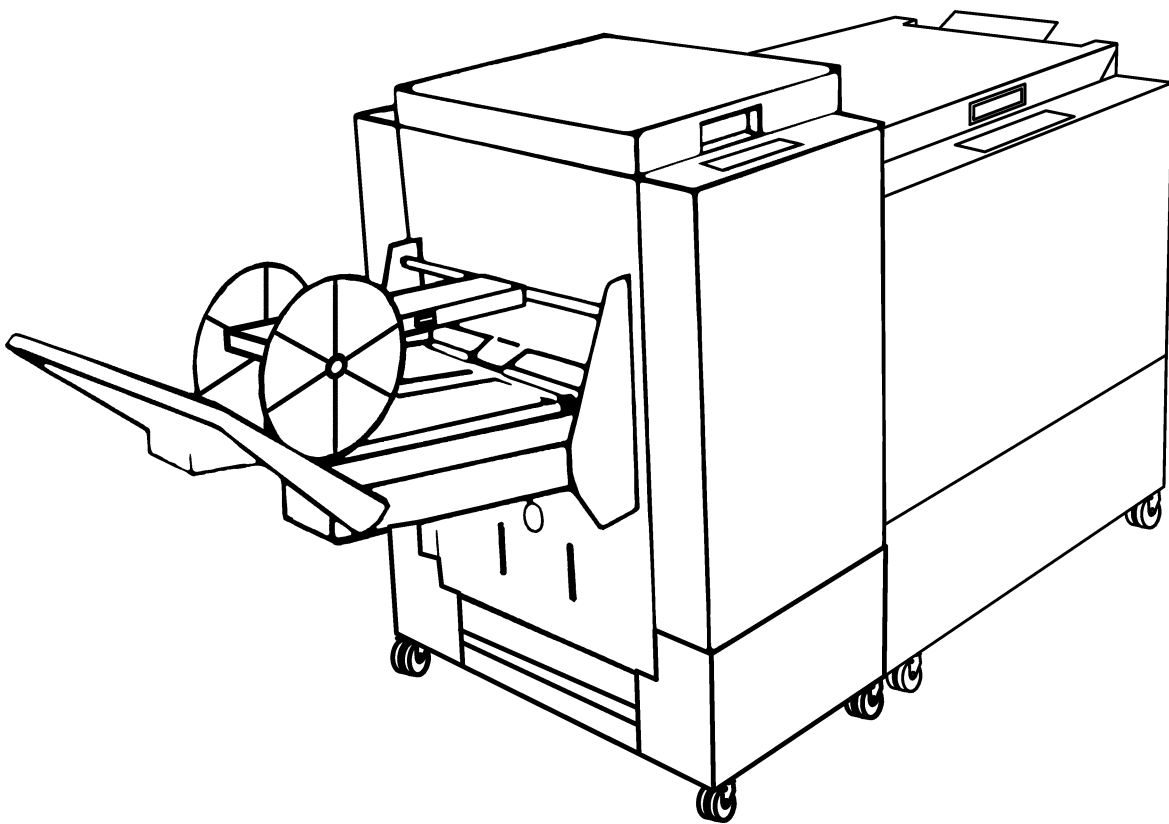

February 2001

Part No. 89004

Contents

REPAIRS/ADJUSTMENTS (REP)		PAGE
REP 3.1	Front cover	3.1.1
REP 3.2	Rear cover	3.2.1
REP 3.3	Upper cover, outfeed side	3.3.1
REP 3.4	Lower cover, outfeed side	3.4.1
REP 3.5	Protective cover	3.5.1
REP 3.6	Deck plate	3.6.1
REP 3.7	Stop carriage	3.7.1
REP 3.8	Exchanging PCB	3.8.1
REP 3.9	Front panel	3.9.1
REP 3.10	Knife motor	(MOT1) 3.10.1
REP 3.11	Transmission motor	(MOT2) 3.11.1
REP 3.12	Adjustment motor	(MOT3) 3.12.1
REP 3.13	Trimmer stop motor	(MOT4) 3.13.1
REP 3.14	Infeed switch	(SW1) 3.14.1
REP 3.15	Control switch infeed, upper shaft	(SW2) 3.15.1
REP 3.16	Stop carriage switch, lower position	(SW4) 3.16.1
REP 3.17	Stop carriage switch, upper position	(SW5) 3.17.1
REP 3.18	Interlock switch	(SW6&7) 3.18.1
REP 3.19	Control switch, outfeed	(SW8) 3.19.1
REP 3.20	Slotted optical switch	(SOS10) 3.20.1
REP 3.21	Outfeed LED and sensor	(LED1&PT1) 3.21.1
REP 3.22	Scrap paper bin LED	(LED2) 3.22.1
REP 3.23	Scrap paper bin sensor	(PR1) 3.23.1
REP 3.24	Knife	3.24.1
REP 3.25	Infeed shaft	3.25.1
REP 3.26	Lower outfeed belts	3.26.1
REP 3.27	Upper outfeed belts	3.27.1
REP 3.28	Transmission chain	3.28.1
REP 3.29	Knife support chain	3.29.1
REP 3.30	Knife chain	3.30.1

ELECTRONIC DETAIL INFORMATION

EDI 4.1	Test points	4.1.1
EDI 4.2	Wiring diagram	4.2.1
EDI 4.3	Electrical components list	4.3.1
EDI 4.4	Electrical components location	4.4.1

FAULT ISOLATING PROCEDURE

FIP 5.1	Fault isolating procedure	5.1.1
---------	---------------------------	-------

PREVENTIVE MAINTENANCE

MAI 6.1	Preventive maintenance	6.1.1
---------	------------------------	-------

REP 3.1 Front cover

REMOVAL

1. Switch off the main power switch and disconnect the power cord.
2. Loosen the two screws (1).
3. Pull the lower side out as indicated in drawing and lift off the cover.
4. Disconnect the ground lead.

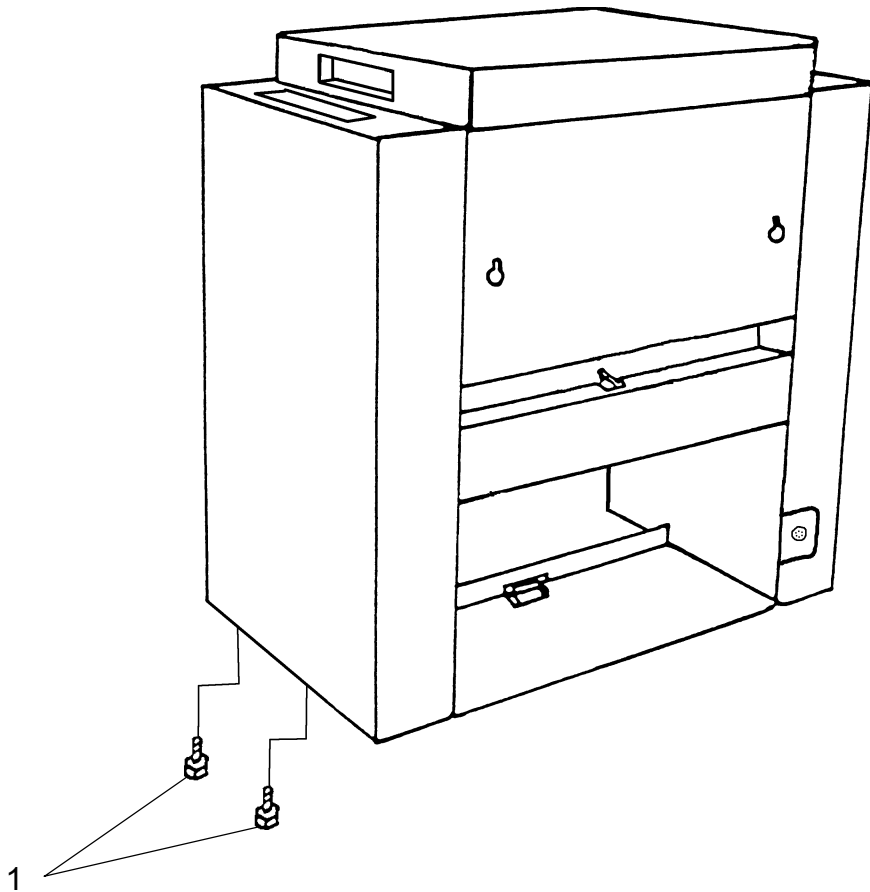

INSTALLATION / ADJUSTMENT

INSTALLATION

Installation is an exact reversed procedure of removal.

WARNING: *Avoid direct light on SOS sensors. It may cause knife motor to start when power is on. Make sure that ground wire is connected.*

REP 3.2 Rear cover

REMOVAL

1. Switch off the main power switch and disconnect the main power cord.
2. Loosen the two screws (1).
3. Pull the lower side out as indicated in drawing and lift off the cover.
4. Disconnect the ground lead.

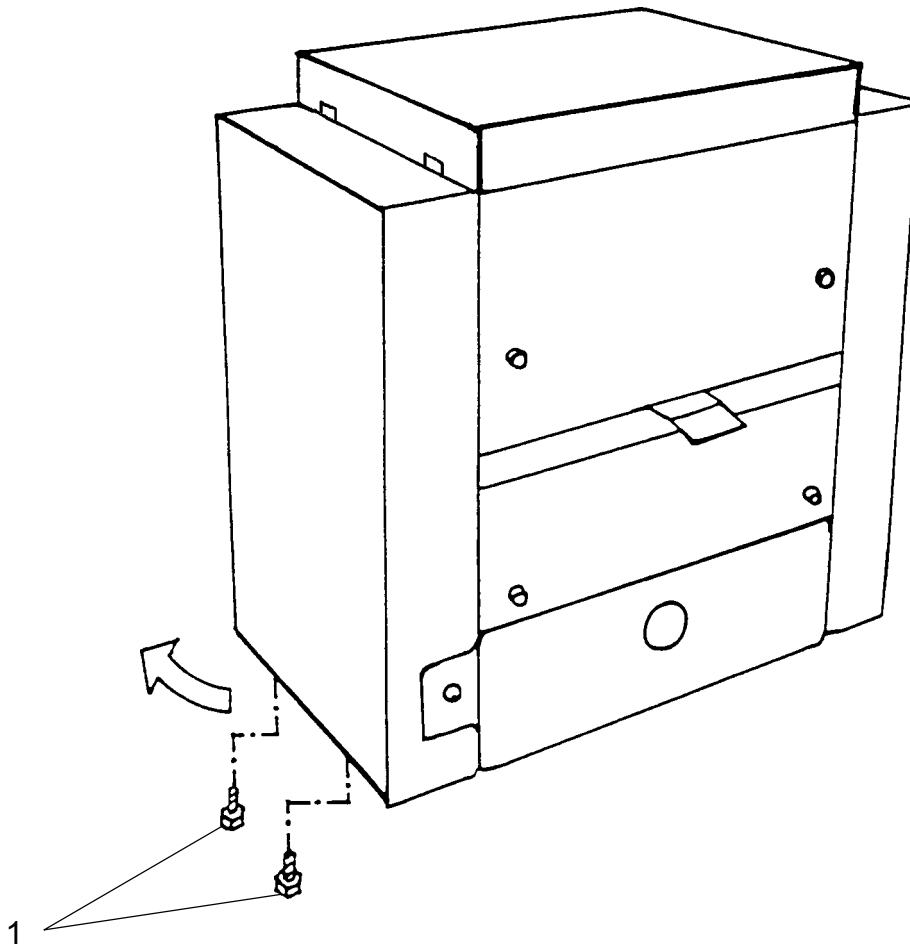

INSTALLATION / ADJUSTMENT

INSTALLATION

Installation is an exact reversed procedure of removal.

WARNING: Make sure ground wire is connected.

REP 3.3 Upper cover, outfeed side

REMOVAL

1. Switch off the main power switch and disconnect the power cord.
2. Remove front and rear cover according to REP 3.1 & 3.2.
3. Open top cover.
4. Remove interlock switches according to REP 3.18 and remove tie-wrap from cover.
5. Remove spring (1) holding compressing brackets.
6. Remove self-tapping screws (8 pcs).
7. Disconnect out feed sensor and remove tie-wraps holding cable.
8. Remove upper cover (2).

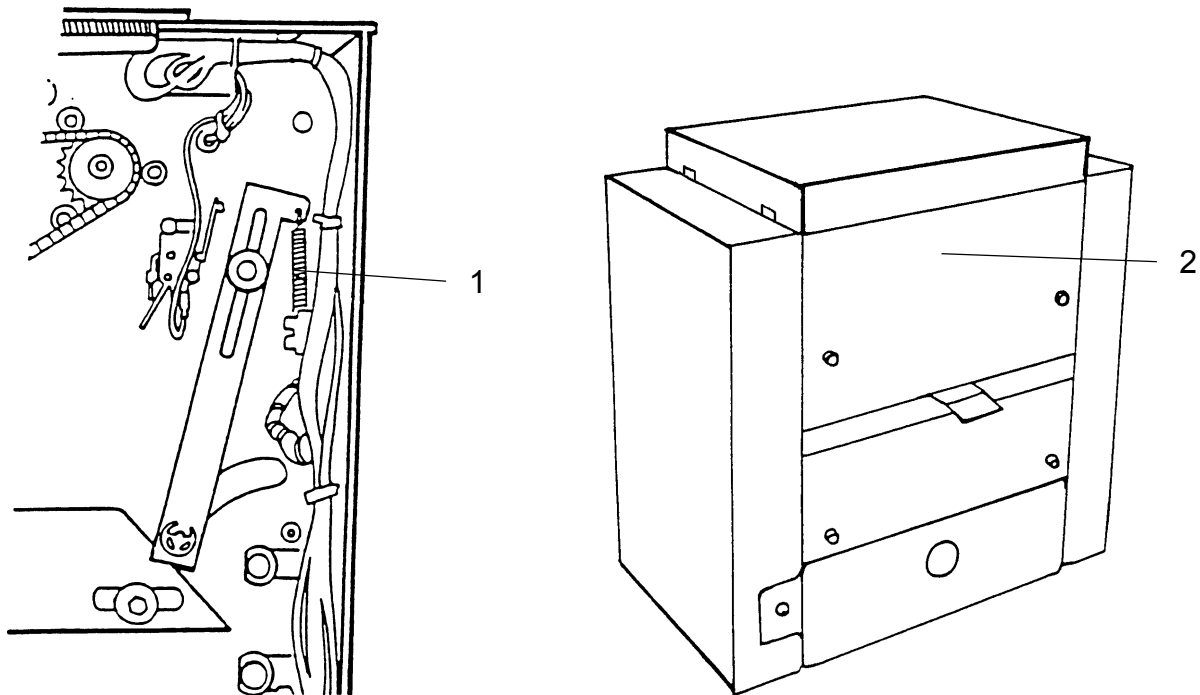

INSTALLATION / ADJUSTMENT

INSTALLATION

1. Connect out feed sensor according to REP 3.21.
2. Mount upper cover.
3. Switch on main power and check voltage on exit sensor according to REP3.21.
4. If sensor is exceeding values, adjust by slightly bending bracket on upper cover.
5. Check interlock function according to REP 3.18.

REP 3.4 Lower cover, outfeed side

REMOVAL

1. Switch off the main power switch and disconnect the power cord.
2. Remove belt stacker.
3. Remove front and rear cover according to REP 3.1 & 3.2.
4. Remove scrap paper bin.
5. Loosen the four screws holding deck plate to cover.
6. Remove the two screws holding protective cover to lower cover.
7. Remove the four screws holding cover to side frames.
8. Remove cover (1).

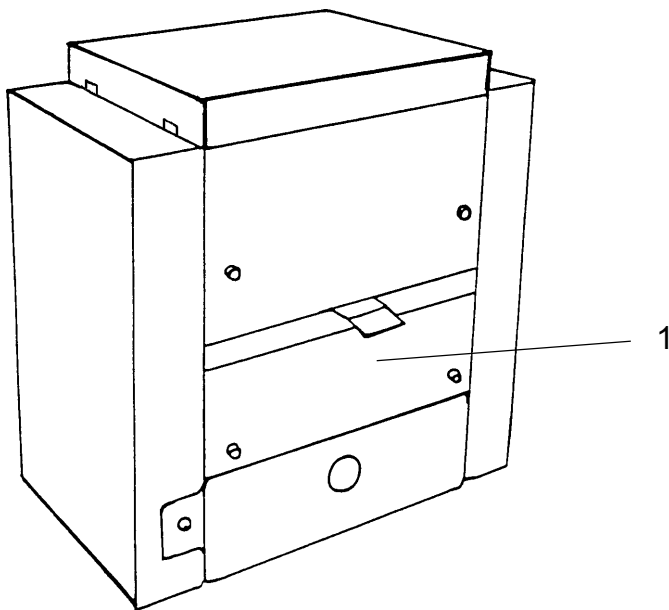

INSTALLATION / ADJUSTMENT

INSTALLATION

Installation is an exact reversed procedure of removal.

REP 3.5 Protective cover

REMOVAL

1. Switch off the main power witch and disconnect the power cord.
2. Remove scrap paper bin.
3. Remove the four screws holding protective cover to lower cover out feed side.
4. Loosen the four screws (10mm wrench) holding protective cover to lower knife beam one turn (do not remove screws).
5. Pull protective cover (1) in out feed direction and remove cover.

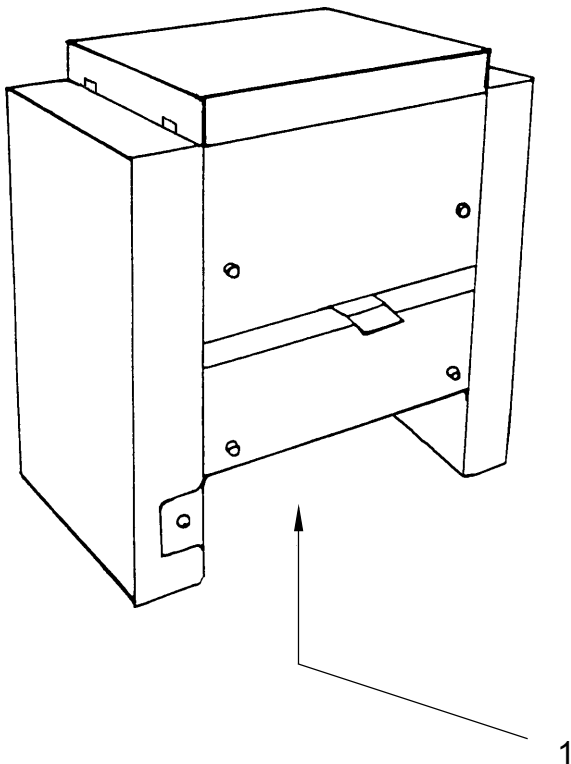

INSTALLATION /ADJUSTMENT

INSTALLATION

Installation is an exact reversed procedure of removal.

CAUTION: *Make sure cover is clear from harnesses when mounting cover.*

REP 3.6 Deck plate

REMOVAL

1. Switch off the main power switch and disconnect the power cord.
2. Open top cover.
3. Move out feed compressing bracket to upper position.
4. Remove screws (1).
5. Remove the six screws holding deck plate to lower cover, out feed side (REP 3.4).
6. Remove deck plate through out feed opening.

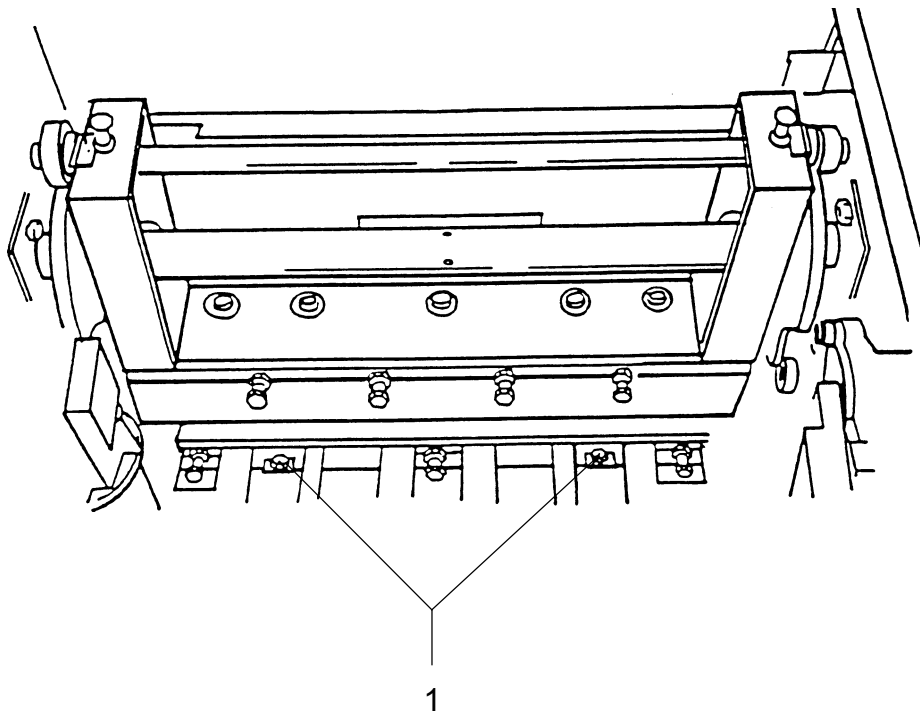

INSTALLATION / ADJUSTMENT

INSTALLATION

Align support rollers on deck plate when mounted.

When compressing foam rollers manually, support rollers should rise 1mm.

CAUTION: Avoid damaging support rollers when deck plate is removed.

REP 3.7 Stop carriage

REMOVAL

1. Position the stop carriage in between A3 and A4 position, adjust on front panel.
2. Switch off the main power and disconnect the power cord..
3. Remove the scrap paper bin.
4. Remove front and rear cover acc. to REP 3.1 and 3.2.
5. Remove the protective cover acc. to REP 3.5.
6. Remove the lower out feed cover acc. to REP 3.4.
7. Disconnect the two connectors (1) from the side frame (not shown in figure).
8. Remove the stop carriage assy. By pulling on the plate (2).

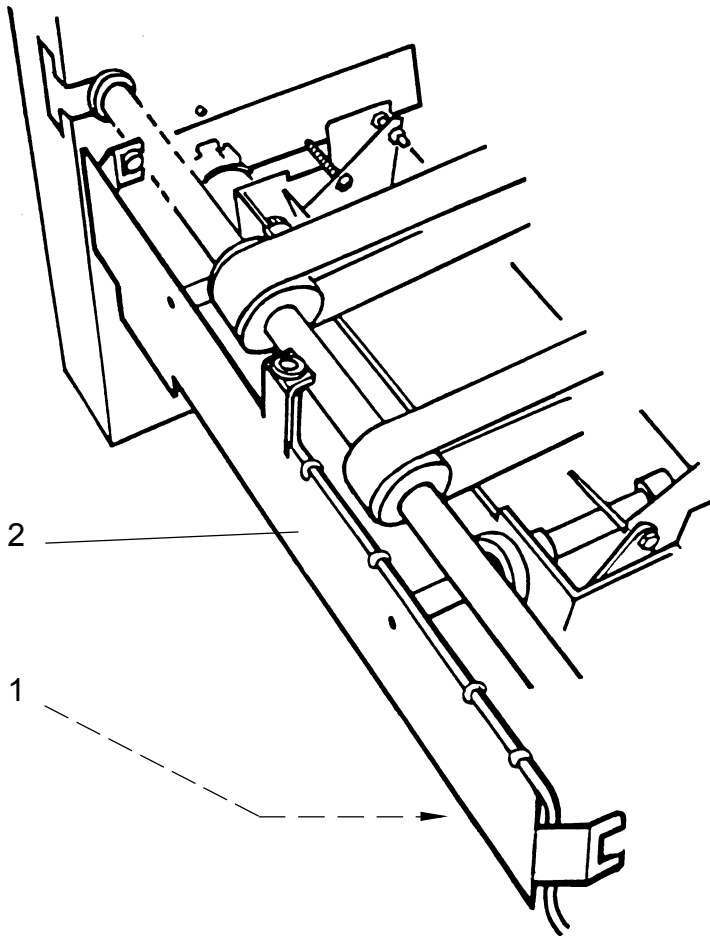

INSTALLATION /ADJUSTMENT

Installation is an exact reversed procedure of removal.

CAUTION: When removing the stop carriage, stay clear from the SOS switches on the circuit board.

REP 3.8 Exchanging PCB

REMOVAL

1. Switch off the main power switch and disconnect the power cord.
2. Remove rear cover according to REP 3.2.
3. Disconnect front panel extension at PCB connector (1).
4. Remove the two nuts and washers (2) and remove the knife position indicator (3).
5. Disconnect the two connectors (4).
6. Remove the four nuts (5) and remove the PCB.

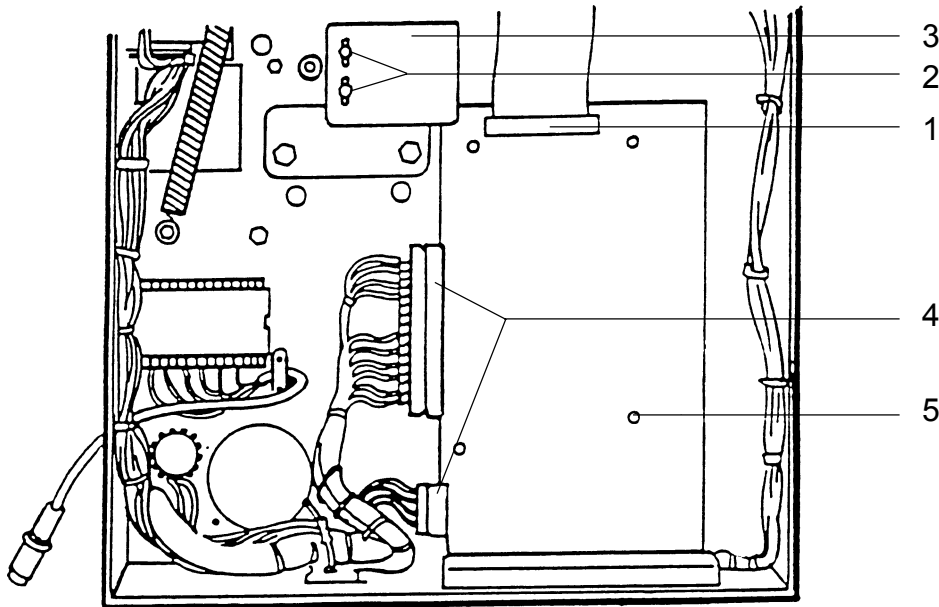

INSTALLATION / ADJUSTMENT

INSTALLATION

1. Mount PCB on to screws.
2. Connect harness and panel connectors.
3. Mount knife position indicator.
4. Make sure that top end of indicator is positioned flush to upper end of upper knife position SOS, when knife is in top position.

REP 3.9 Front panel

REMOVAL

1. Switch off the main power and remove the power cord.
2. Remove front cover according to REP 3.1.
3. Disconnect the panel from the adaptor board.
4. Remove the old panel, the panel is mounted with self-adhesive tape. (When tearing off, the panel will be damaged.)

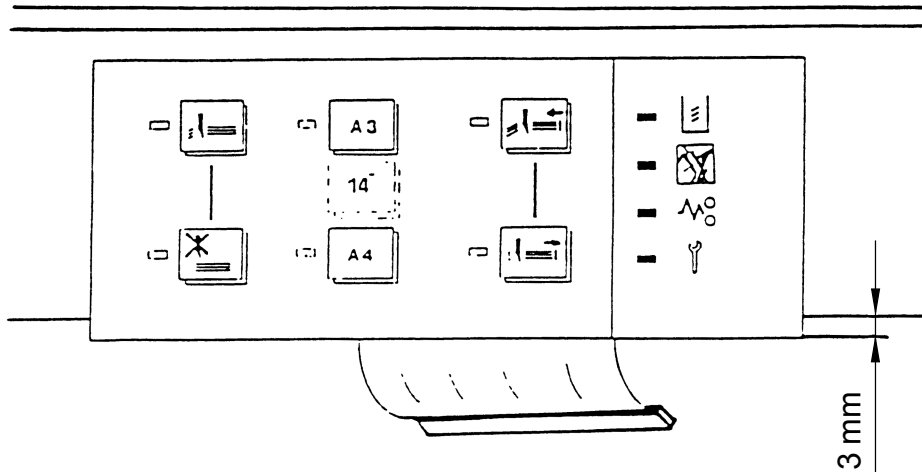

INSTALLATION / ADJUSTMENT

INSTALLATION

1. Clean top surface of side frame with alcohol cleaner and remove protective film on back of new panel.
2. Place the panel cantered sideways (80mm from edges) and 3mm off the edge according to figure above.
3. Connect the panel to adaptor board.

REP 3.10 Knife motor (MOT1)

REMOVAL

1. Switch off the main power and remove the power cord.
2. Remove rear cover according to REP 3.2.
3. Disconnect the wires from the motor at the terminal block (positioned on side of frame).
4. Use a 13 mm wrench to turn camshaft (1) clockwise until the knife is in lower position.
5. Remove knife chain according to REP 3.30.
6. Remove the sprocket (2) by loosening the two setscrews holding the sprocket to the motor shaft and pull off the sprocket.
7. Remove the three screws (3) and lift out the motor.

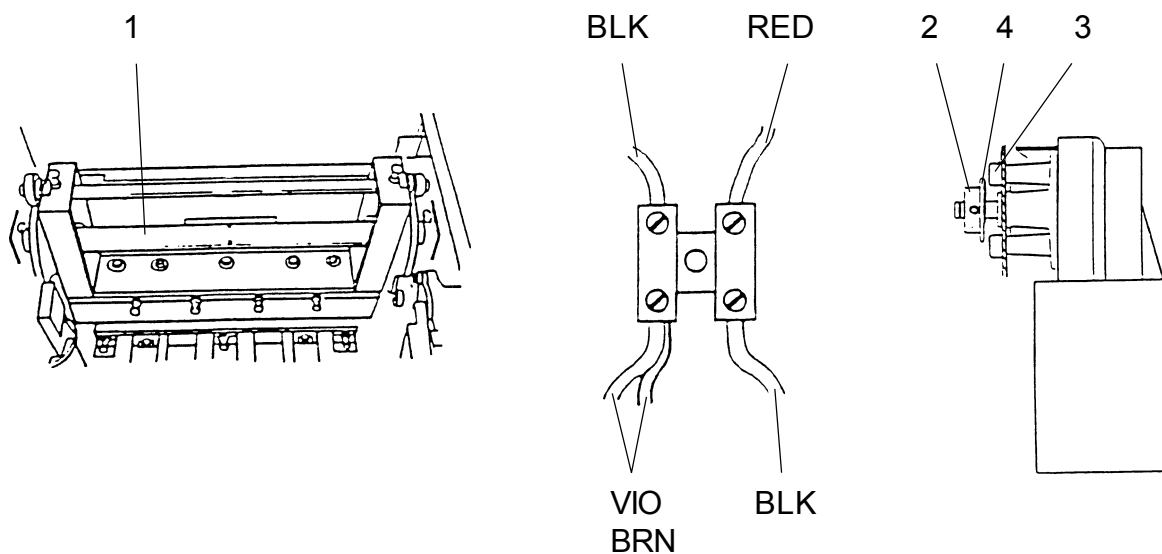

INSTALLATION / ADJUSTMENT

PURPOSE

The purpose is to ensure correct drive to the camshaft without any slack in the drive chain.

ADJUSTMENT

1. Mount the motor to the side frame, without tightening the screws, and connect the wires to the terminal block according to figure.
2. Mount the sprocket (2) all the way into the clamp ring (4) and tighten the setscrews. One of the sets screws have to be in the key-way of the shaft.
3. Tension the knife chain by moving the motor (5) and tighten the screws (3). There should be NO slack in the knife chain.

WARNING: *Stay clear from knife edge when turning camshaft and disengaging drive chain.*

REP 3.11 Transmission motor (MOT2)

The main function on MOT 2 is main drive for feed belts.
By alter the polarity the reverse direction will function as a support motor for MOT 1
During the lower part of the cutting stroke.

REMOVAL

1. Switch off the main power and remove the power cord.
2. Remove front cover according to REP 3.1.
3. Disconnect the wires from the motor at the terminal block (fig. 2) positioned on side of frame.
4. Remove the four screws (6).
5. Remove the support plate (7) by pulling it off the shaft assy (2).
6. Remove the transmission chain and knife support chain according to REP 3.28 and 3.29.
7. Remove the shaft assy (2) by pulling it out. The shaft assy is mounted with a wedge.
(Note the shim washers location when removing the shaft.)
8. Remove the three screws (3) and lift out the motor.

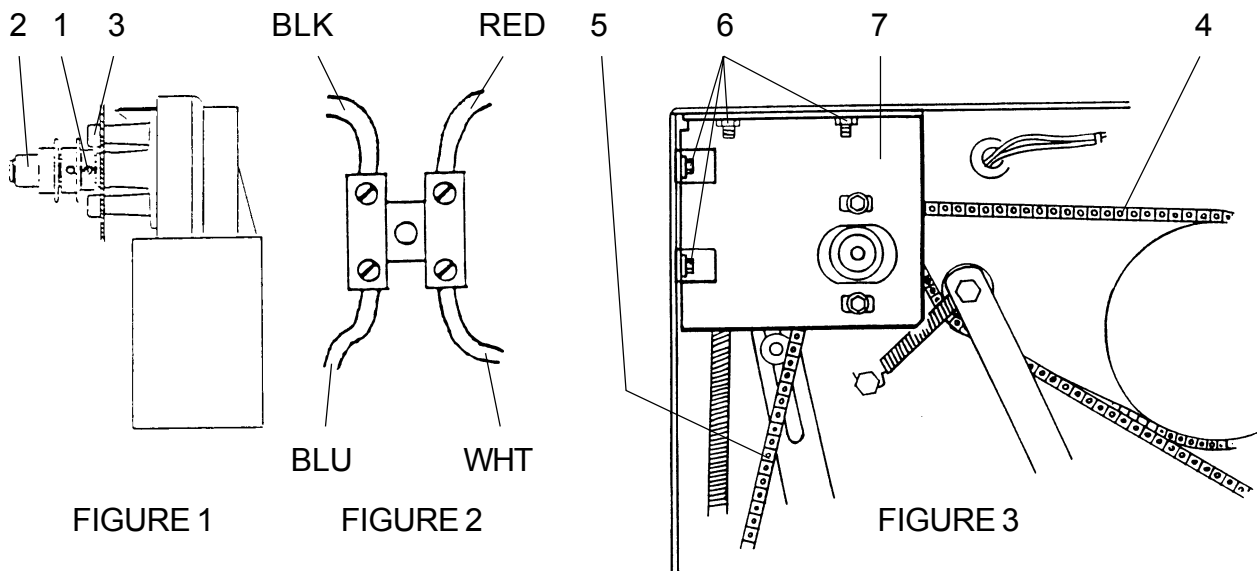

INSTALLATION / ADJUSTMENT

PURPOSE

The purpose is to endure the correct drive without any slack in drive chains.

ADJUSTMENT

1. Mount the motor to the side frame without tightening the screws (3).
2. Place the shim washer on to the motor shaft.
3. Mount the shaft assy (1) all the way into the motor hub.
4. Mount the knife support chain (4) according to fig. 3.
5. Tension the chain (4) by moving the motor and tighten the screws (3).
6. Mount the transmission chain (5) according to REP 3.28.
7. Mount the support plate (7). The bushing in the support plate can be adjusted up/down for alignment.
8. Connect wires from motor according to fig.2.

REP 3.12 Adjustment motor (MOT3)

REMOVAL

1. Switch off main power and remove the power cord.
2. Remove the stop carriage according to REP 3.7.
3. Remove the return spring (2).
4. Disconnect the connector (1).
5. Loosen the four nuts (3) and remove the motor. (The motor is fitted into keyholes.)

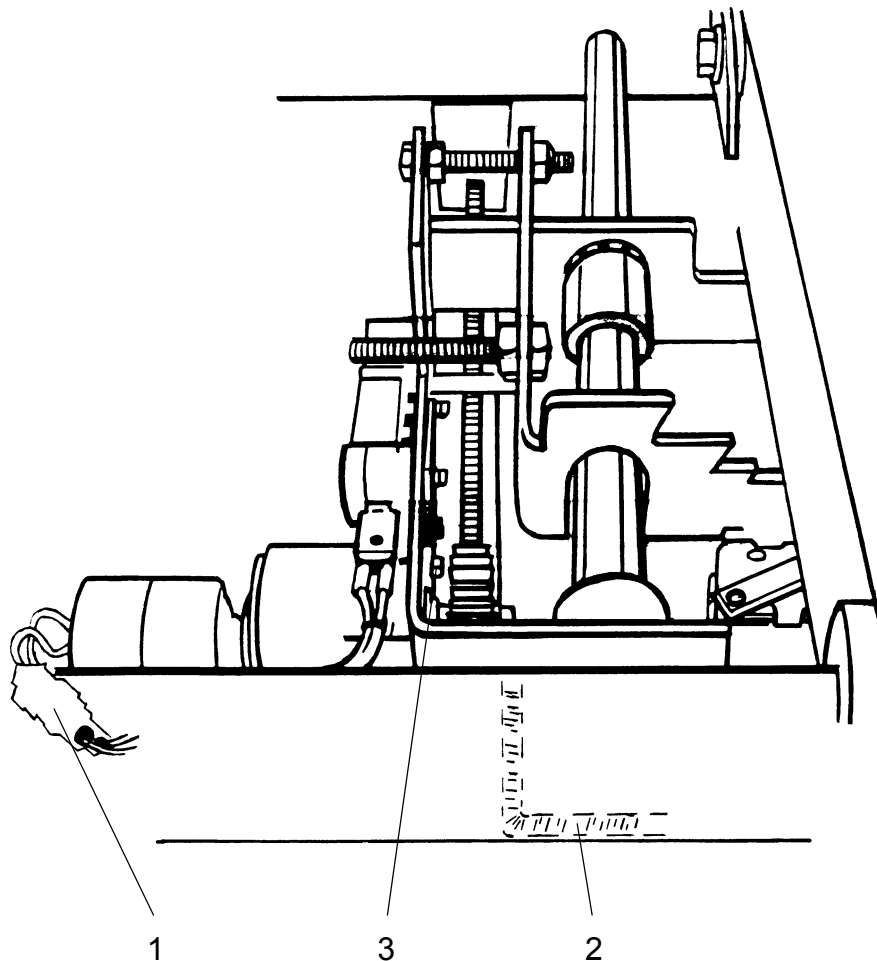

INSTALLATION/ADJUSTMENT

Installation is an exact reversed procedure of removal.

CAUTION: When installing, make sure that the wires from the motor stays clear from SOS switches when moving the carriage.

REP 3.13 Trimmer stop motor (MOT4)

REMOVAL

1. Switch off the main power and disconnect the power cord.
2. Remove the stop carriage according to REP 3.7.
3. Remove tie-wrap and disconnect the connector (1).
4. Loosen the four nuts (2) and remove the motor while lifting the plastic guide (3) off the scored pulley (4).

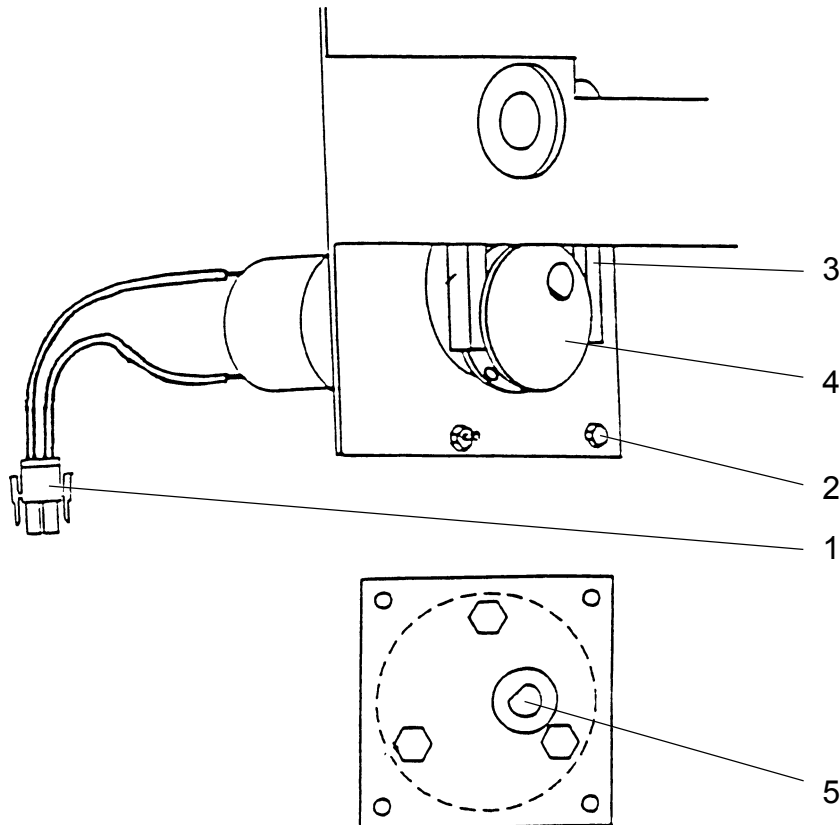

INSTALLATION/ADJUSTMENT

PURPOSE

The purpose is to ensure that the pulley moves freely in the plastic guide.

ADJUSTMENT

1. Place the shaft (5) according to figure when mounting motor.
2. Align the pulley with the plastic guide and tighten the setscrew on to the cut out part of the shaft.

NOTE: Motor is fitted into keyholes.

REP 3.14 Infeed switch (SW1)

The function of the switch is to set a control time to check if the books are too long for the adjusted cutting margin or is miss folded.

REMOVAL

1. Switch off the main power and remove the power cord.
2. Open top cover.
3. Remove scrap paper bin.
4. Remove protective cover according to REP 3.5.
5. Disconnect the connector (1).
6. Loosen the two 7mm nuts (2) holding the switch bracket (3).
7. Lift out switch bracket (3) and remove the switch.

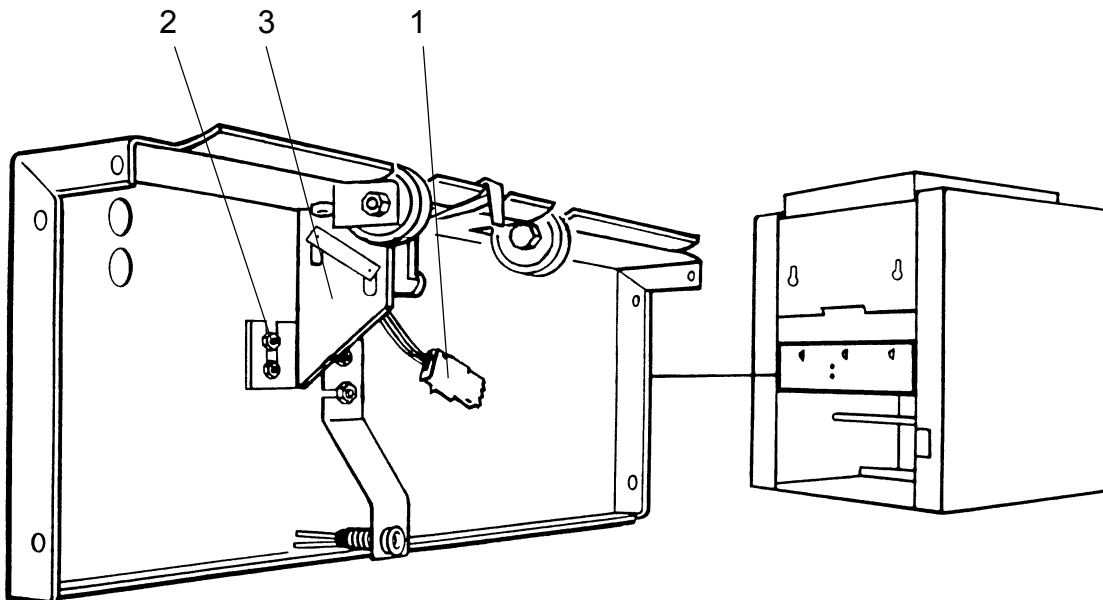

INSTALLATION/ADJUSTMENT

ADJUSTMENT

The switch should activate when inserting one 80gsm offset paper.

Check that no part of the switch is over the paper path when switcharm is in fully down position. Check that the switch arm does not touch the wheel on in feed shaft when not activated.

REP 3.15 Control switch infeed, upper shaft (SW2)

REMOVAL

1. Switch off the main power and disconnect the power cord.
2. Remove rear cover according to REP 3.2.
3. Disconnect the wires from the switch.
4. Remove the two screws (1) and lift out the switch.

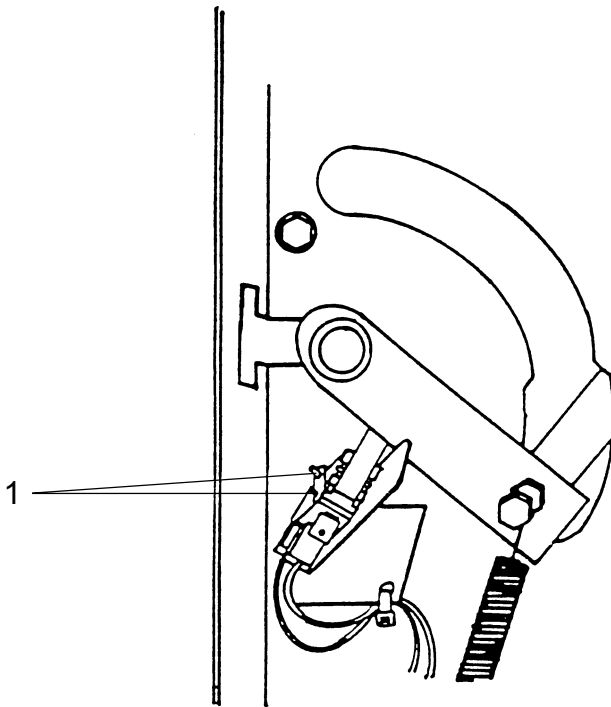

INSTALLATION/ADJUSTMENT

ADJUSTMENT

1. The micro switch should trip when roller is 1-3mm above lower position (measured while closing).
2. Connect the wires according to the drawing.

REP 3.16 Stop carriage switch, lower position (SW4)

REMOVAL

1. Switch off the main power and remove the power cord.
2. Remove the stop carriage according to REP 3.7.
3. Disconnect the wires from the switch.
4. Remove the two screws (1).

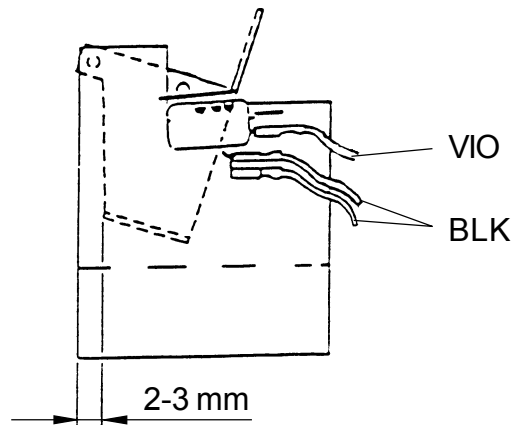
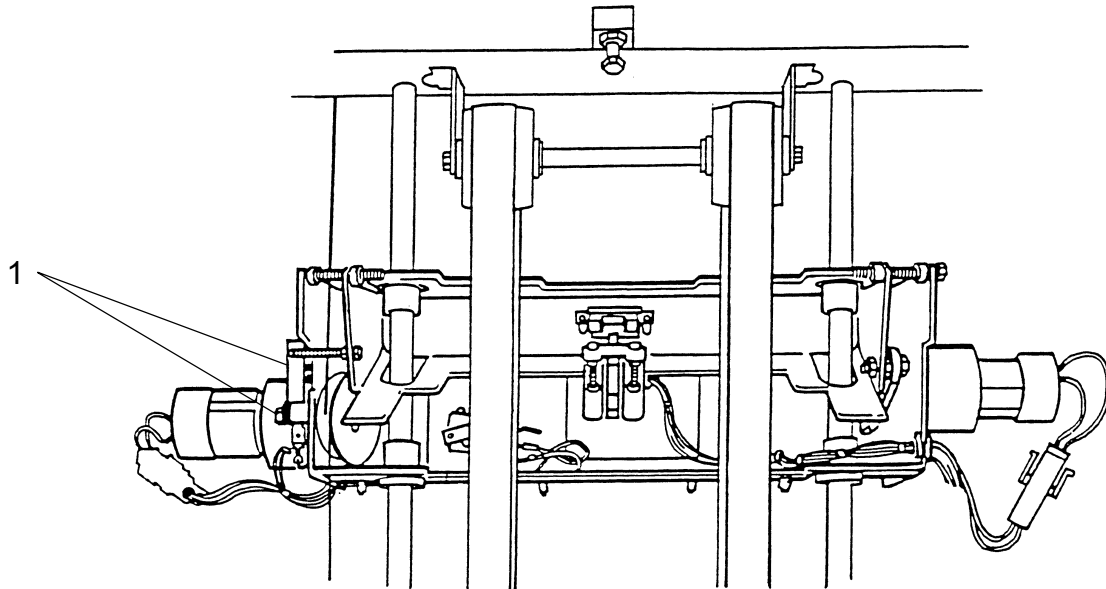

INSTALLATION/ADJUSTMENT

ADJUSTMENT

1. The micro switch should activate when the stop fork is 2-3mm from the stop carriage plate (2) according to fig. 2.
2. Connect the wires according to fig. 2.

REP 3.17 Stop carriage switch, upper position (SW5)

REMOVAL

1. Switch off the machine and disconnect the power cord.
2. Remove the stop carriage according to REP 3.7.
3. Disconnect the two wires from the switch.
4. Remove the screws (1).

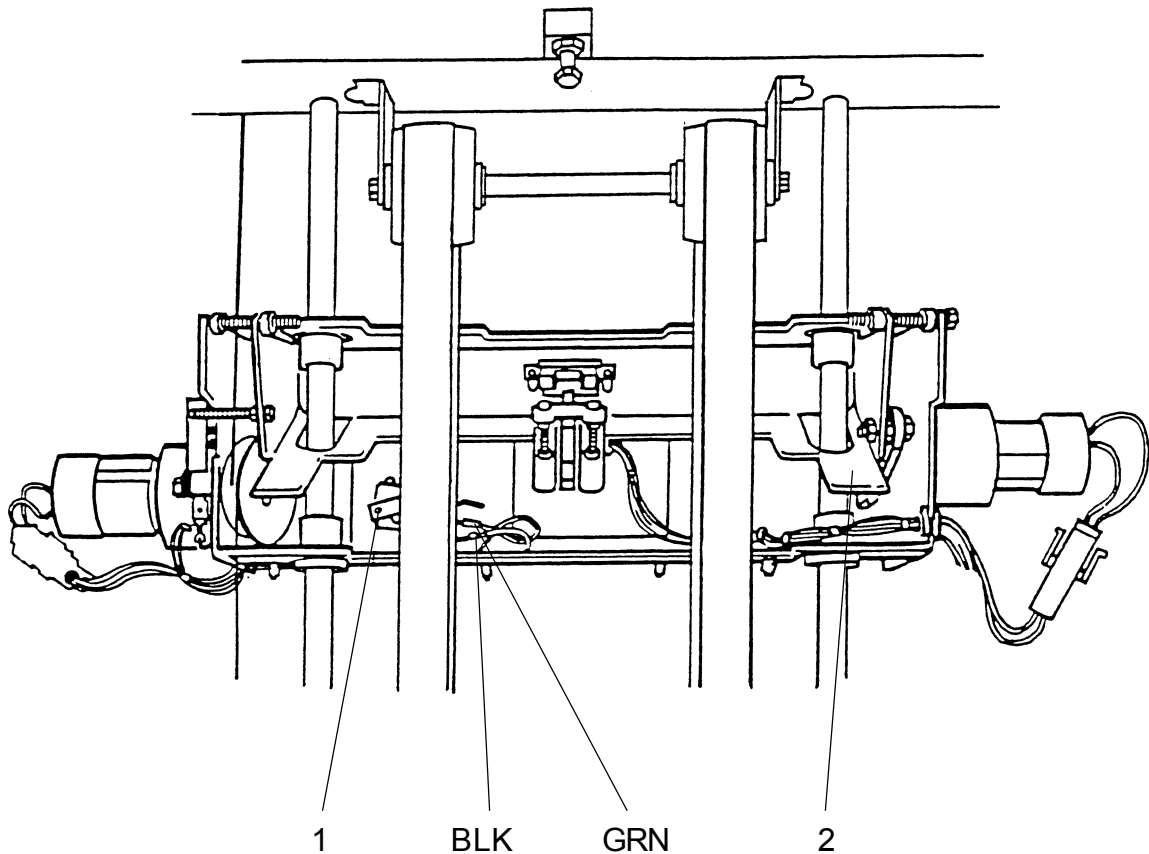

INSTALLATION/ADJUSTMENT

PURPOSE

The purpose is to ensure correct position of the trimmer stop.

ADJUSTMENT

1. The micro switch should activate just before top position of the trimmer stop (2).
2. Connect the wires according to figure.

REP 3.18 Interlock switch (SW6 & 7)

REMOVAL

1. Switch off the main power and remove the power cord.
2. Open top cover.
3. Loosen the two screws (1) and remove the interlock assy. The interlock assy. is fitted into key holes on the inside of the upper cover, outfeed side.
4. Disconnect the wires.

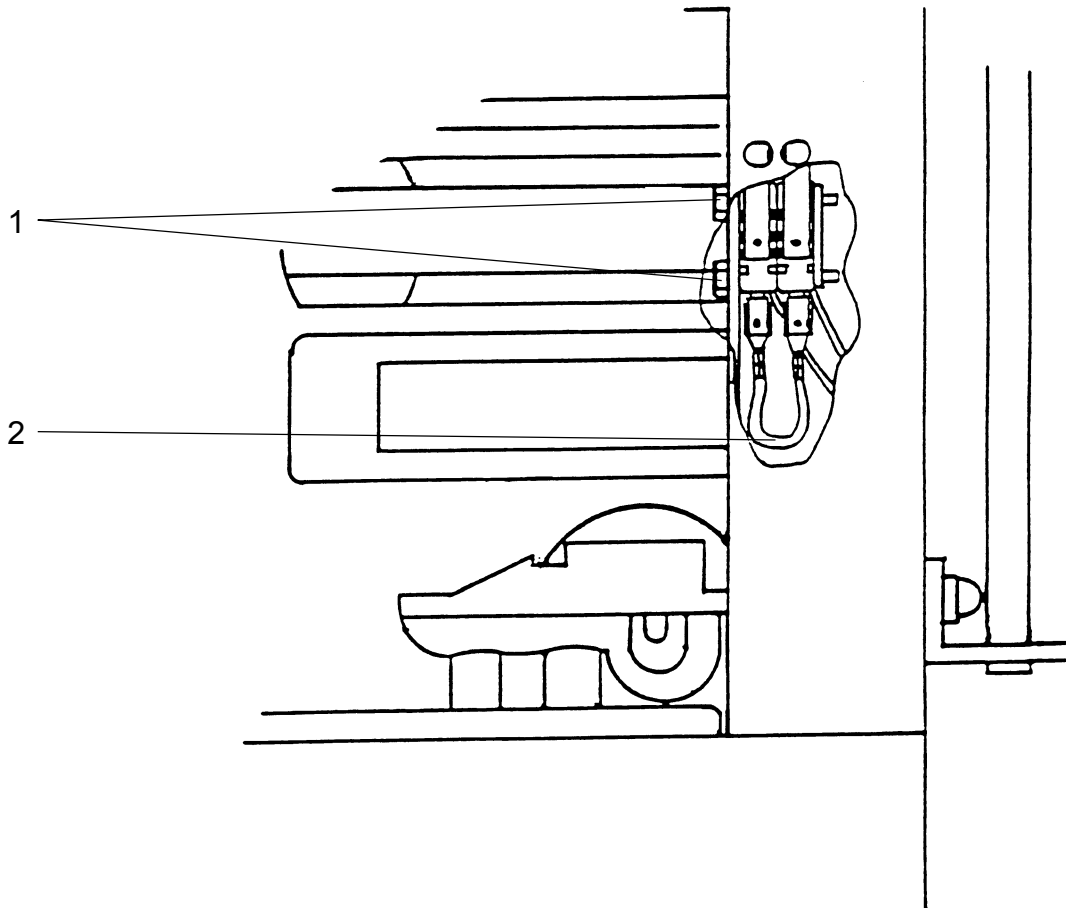

INSTALLATION/ADJUSTMENT

ADJUSTMENT

1. Connect jumper wire (2) to the middle pins on both switches.
2. Connect the orange and red wire to the two lower pins.
3. Mount the interlock switches into the keyholes and tighten the screws (1).
4. Remove rear cover according to REP 3.2.
5. Check interlock function by measuring resistance between red and orange wire on terminal block, mounted on side frame next to PWB. Value should be less than 0,5 ohms with top cover closed. There should be no connection when top cover is open.

NOTE: Make sure that service switch is in "off" position when checking interlock switches.

REP 3.19 Control switch outfeed compressing bracket (SW8)

SW8 function is to unable running of the machine with the compressing bracket in Upper position.

REMOVAL

1. Switch off the main power and disconnect the power cord.
2. Remove the rear cover according to REP 3.2 and open the top cover.
3. Disconnect the wires from the switch.
4. Remove the two screws (1) and lift out the switch and insulating plate.

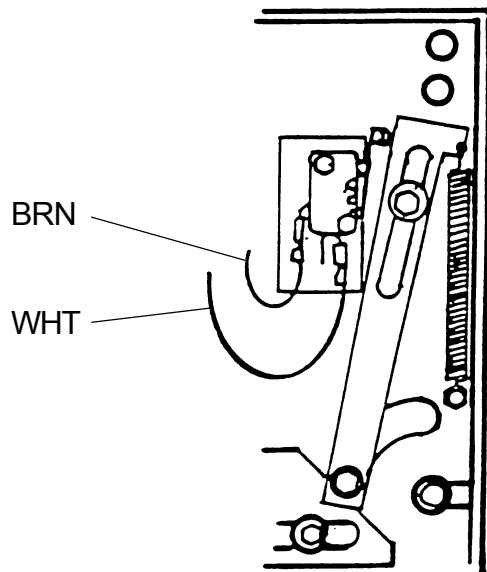

INSTALLATION/ADJUSTMENT

ADJUSTMENT

1. The micro switch should activate when the middle compressing bracket is 2-8mm from upper lock position.
2. Connect the wires according to figure above.

NOTE: *Fit nut plate onto top screw while holding other end of nut plate. Then swing nut plate to correct position and fit the other screw.*

REP 3.20 Slotted optical switch (SOS10)

REMOVAL

1. Switch off the main power switch and disconnect the power cord.
2. Remove the stop carriage according to REP 3.7.
3. Note position of connectors and disconnect them.
4. Remove screws and washers (1) while holding SOS with a pair of pliers.
5. Lift out SOS between trimmer stop and stop carrier.

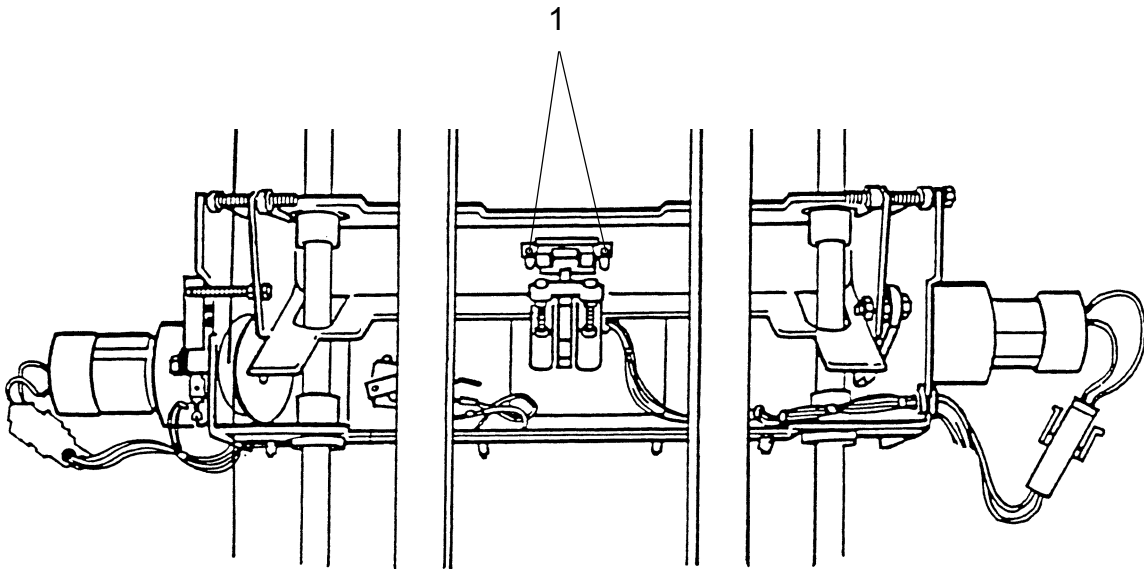

INSTALLATION/ADJUSTMENT

INSTALLATION

1. Note diode mark on top of SOS, before mounting.
2. Mount the SOS with the diode mark turned as indicated in the drawing.
3. Connect the SOS according to the drawing.
4. Remove rear cover according to REP3.2.
5. Connect power cord and switch on main power.
6. Connect a V-meter between TP3 on PCB PL89-1 and common, select DC voltage.
7. Press the switch activator manually until it is flush with the trimmer stop, the sensor is now blocked, the value should be less than 1 volt.
8. With the optical path clear, the value should be more then 14 volt.

CAUTION: *The pins on the SOS are fragile, do not use excessive force when mounting.*

REP 3.21 Outfeed LED & sensor (LED1 & PT1)

REMOVAL

Switch off the main power and remove the power cord.

Remove sensor, fig. 1.

1. Pull the connector (1) off the pins from the sensor.
2. Remove the nut (2).

Remove LED, fig. 2.

1. Remove lower cover out feed according to REP 3.5.
2. Remove the stop carriage according to REP 3.8.
3. Pull the connectors off the pins from the LED (3).
4. Remove the nut (4).

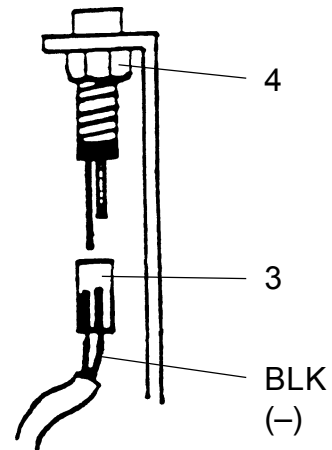
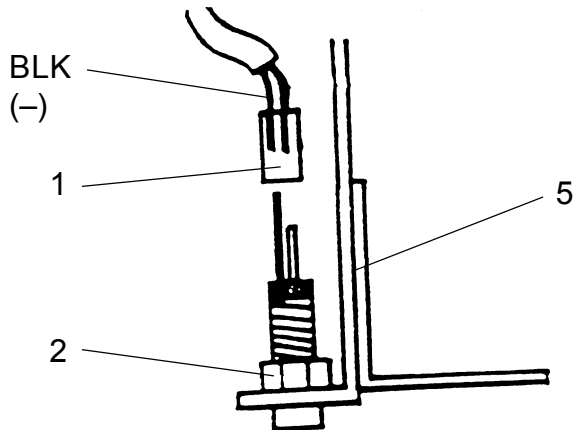

INSTALLATION/ADJUSTMENT

PURPOSE

The purpose is to ensure that the correct output sensor voltage is obtained.

ADJUSTMENT

1. With the optical path from the LED to sensor clear, check that there is more than 10 VDC measured between TP4 on PCB PL89-1 and common. With the path blocked, the voltage should be less than 1 VDC.
2. Move the sensor bracket (5) to obtain the correct voltage.

REP 3.22 Scrap paper bin LED (LED2)

REMOVAL

Switch off the main power and remove the power cord.

1. Remove scrap paper bin.
2. Pull the connector (1) off the pins from the LED.
3. Remove the 10mm nut and remove LED assy (2) from LED bracket (3).

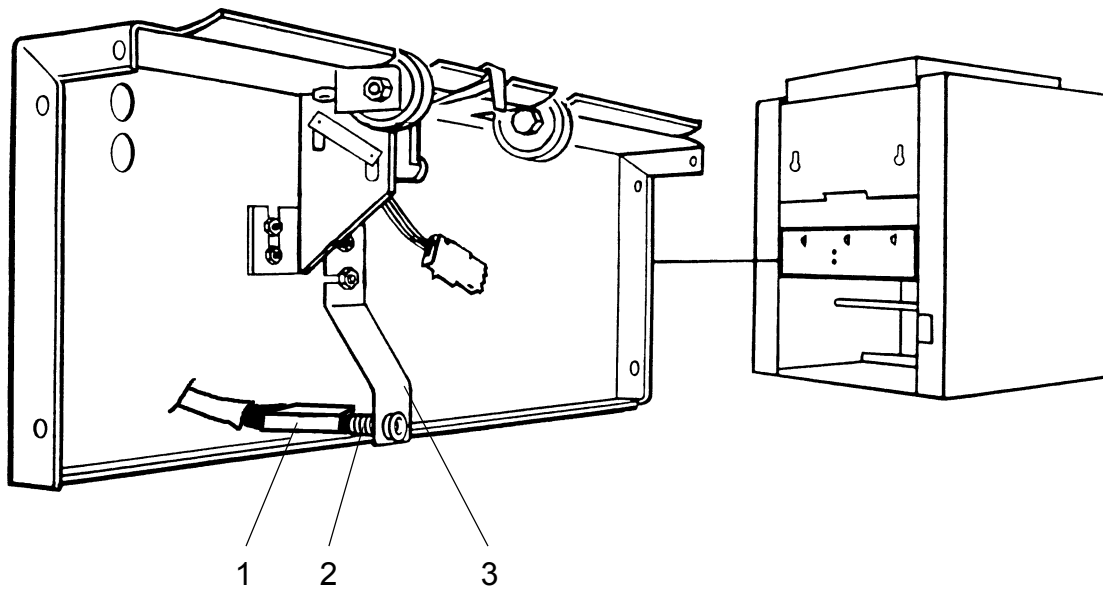

INSTALLATION/ADJUSTMENT

PURPOSE

The purpose is to ensure that the correct sensor voltage is obtained.

ADJUSTMENT

1. Mount the LED assy in bracket.
2. Connect short pin on LED with blue wire on connector (ground).
3. Remove rear cover according to REP 3.2.
4. Connect the power cord and switch on the main power.
5. Connect a V-meter between TP6 and common on PCB PL89-1. the value should be min. 8 VDC with the optical path to the sensor clear. With the light beam blocked, the voltage should be max. 3.5 VDC. Adjust on trimmer TR1.

NOTE: Colours on wires can also be brown and black. Black is equal to blue.

WARNING: Avoid direct light on SOS sensors.

It may cause knife motor to start when power is on.

REP 3.23 Scrap paper bin sensor (PR1)

REMOVAL

1. Switch off the main power switch and disconnect the power cord.
2. Remove the scrap paper bin.
3. Pull the connector 1 off the pins of the photoreceiver.
4. Remove the photoreceiver assy by removing the two 6mm nuts located behind the plate 2.

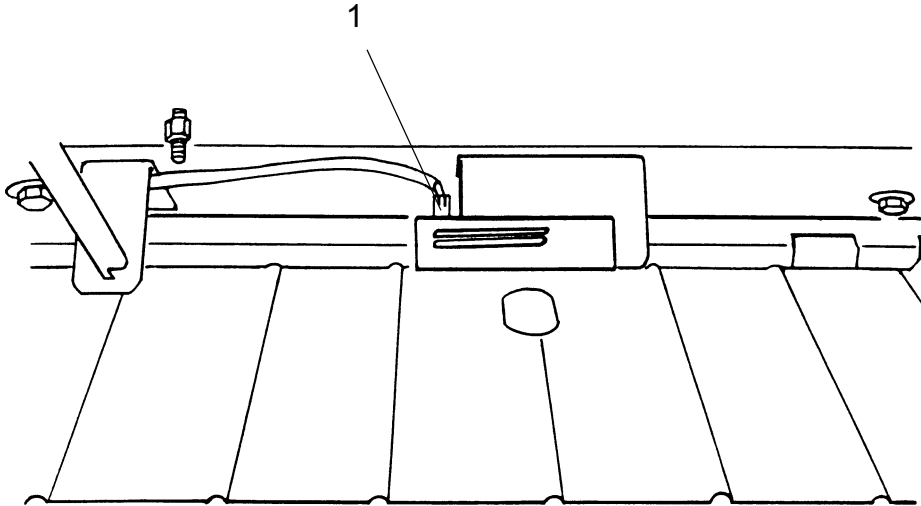

INSTALLATION/ADJUSTMENT

Installation is an exact reversed procedure of removal.

NOTE: After installing check adjustment of sensor according to REP 3.22.

REP 3.24 Knife

REMOVAL

1. Switch off the main power switch and disconnect the power cord.
2. Remove the belt stacker.
3. Lift off the TR85 from the SR85.
4. Lift the outfeed compressor assembly to upright position.
5. Remove the upper infeed cover.
6. Remove protective cover according to REP 3.5.

WARNING: Stay clear from upper knife. The knife edge may cause serious injuries. Use the safety block (14) to put between lower knife and upper knife beam as much of the time as possible throughout this REP.

Upper knife

7. Place the safety block (14) between lower knife and upper knife beam.
NOTE: The safety block is located inside the rear cover by the interlock bypass switch.
8. Remove knife protection plate (7) by removing the three screws (2).
9. Move transport protection from the new to the old knife or use the transport protection supplied in the Trimmer installation kit.
10. Release the set clamp by releasing the E-clip on the middle plunger.
11. Remove the six screws (4) with the cup spring washers.

NOTE: When removing screws the nuts (7) will fall down through the cut-out in bottom of knife beam.

12. Lift out the upper knife.

Lower knife

7. Remove the four screws (11) in the middle with the washers.
8. Remove the two screws (11) at each end of the knife with cup spring washers.
9. Lift out the lower knife.

INSTALLATION

Upper knife

1. Move transport protection from the old to the new knife.
2. Clean and apply grease on guide bars (6) and side guides (3).
3. Fit knife onto guide bars.
Apply grease on the cup spring washers closest to the knife.
Mount screws (4).
4. Remove transport protection and mount it on the old knife.
5. Mount knife protection plate (7).
6. Mount the set clamp.

Lower knife

1. Place the lower knife onto the lower knife beam.
2. Apply grease on all washers.
3. Mount the two screws (11) at each end of the knife with cup spring washers.
4. Mount the four screws (11) in the middle with the washers.

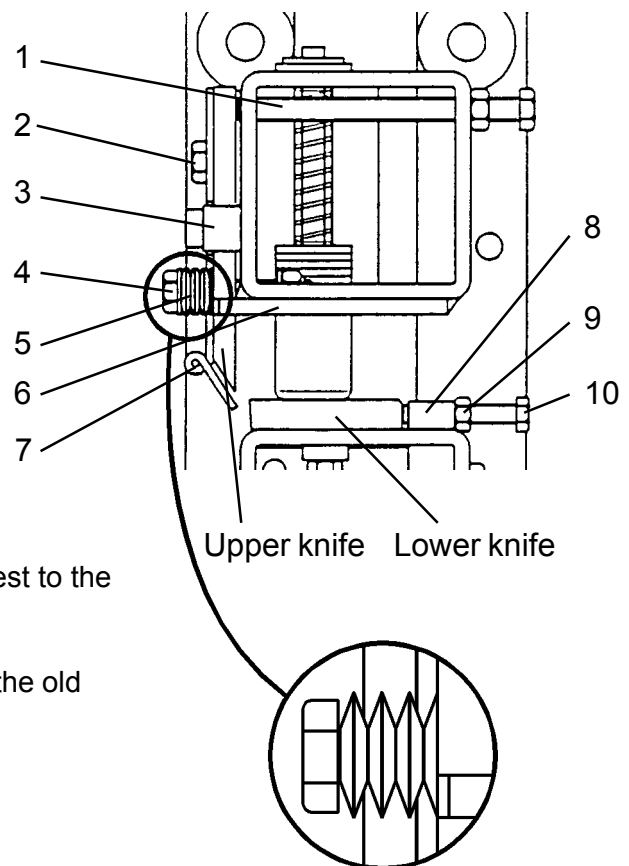

REP 3.24 Knife, continues

ADJUSTMENT

1. Turn the six mounting screws (4) so there is no tension and no play between cup spring washers and upper knife.
Then turn the mounting screws (4) one revolution clockwise.
2. Loosen the nuts (9) and turn the three adjustment screws (10) fully counter clockwise.
Loosen the six mounting screws (11) on lower knife.
Push the lower knife against the bracket (8).

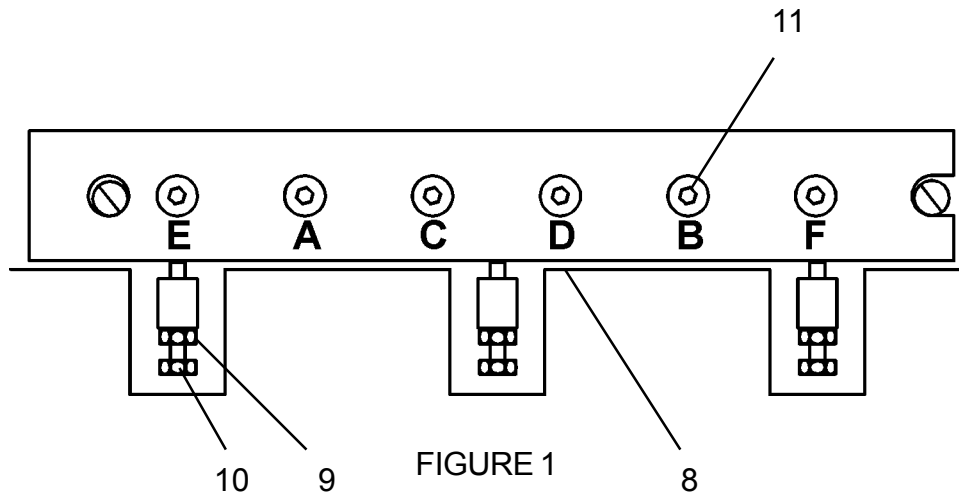

3. Use the safety block (14) to put between lower knife and upper knife beam as much of the time as possible throughout this adjustment.
4. Use a feeler gauge and check that the space (12) between upper knife and the two red marked screws in the middle (1) is 0.50 mm.
Adjust the space if necessary on the two outer adjustment screws and nuts (1).

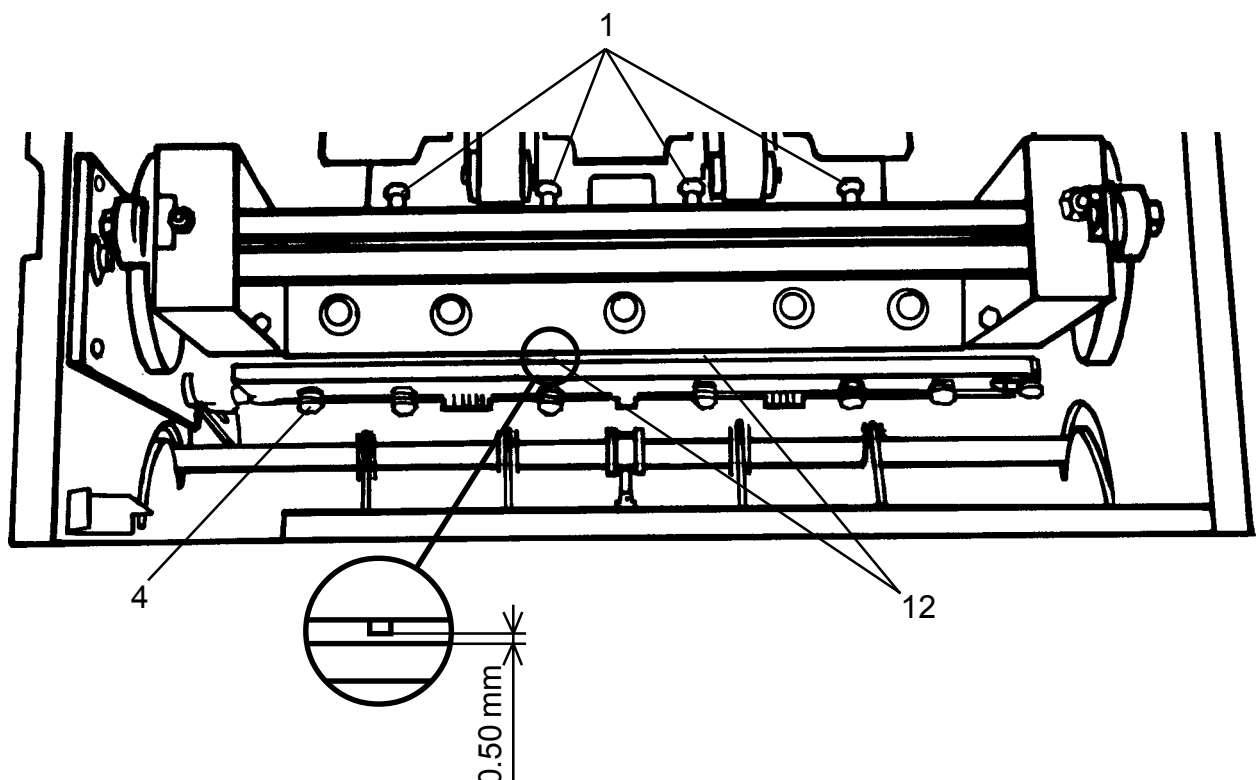

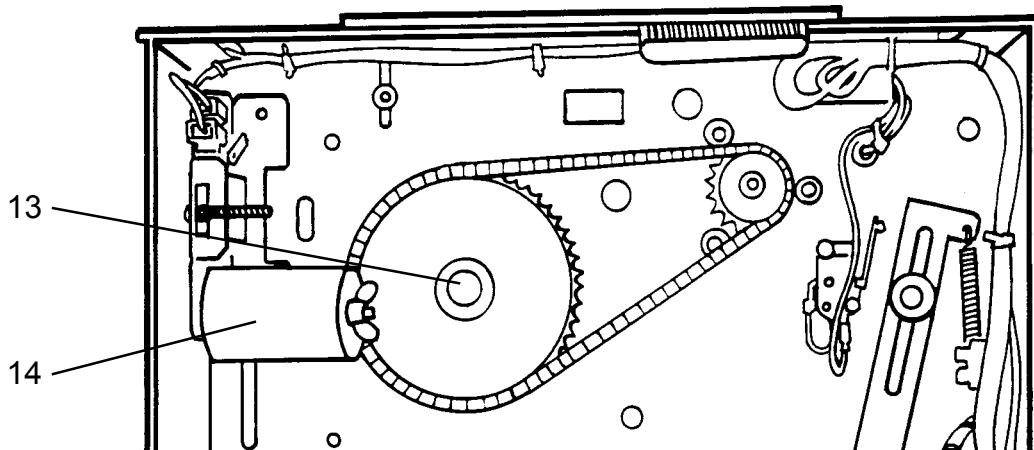

5. Lower the upper knife to the bottom position by turning crank shaft (13) using a 13 mm wrench.
Caution: When bringing the upper knife down make sure it does not touch the lower knife.
6. Push in the lower knife against the upper knife a couple of times on both ends to make sure it is against the upper knife at the whole cutting area.
7. Raise the upper knife to the top position by turning crank shaft (13).
8. First tighten the screws (11) a little according to the sequence A-F Figure 1.
Then tighten a little harder to finally fully tighten the screws according to the sequence.
9. Turn the adjustment screws (10) so they touches the lower knife.
10. Slowly and carefully without paper lower the upper knife to the bottom position by turning crank shaft (13). If the upper knife touches the lower knife, back up the upper knife and start over from step 2.

NOTE: Look through the cut out in the side frame while turning crank shaft.

11. Make a two sheet folded (or staple and folded) A3 (11"x17") 80 gsm set and place it in cutting position.
Trim the set by turning crank shaft (13).

NOTE: Use the SR85 to staple and fold the required sets.

12. If the set is not correctly cut on one of the ends, loosen the five mounting screws (11) on that end and keep the one mounting screw tightened at the good end.
Turn the adjustment screw (10) on the bad end $1/36$ revolution or 10° . See figure 2.
Repeat step 8 and 9, then return to this step until it cuts clean on the sets both ends.
13. Make a 15 sheet folded (or staple and folded) A3 (11"x17") 80 gsm set and place it in cutting position.
Trim the set by turning crank shaft (13).
Repeat step 12.
14. Make a 20 sheet folded (or staple and folded) A3 (11"x17") 80 gsm set and place it in cutting position.
Trim the set by turning crank shaft (13).
Repeat step 12.

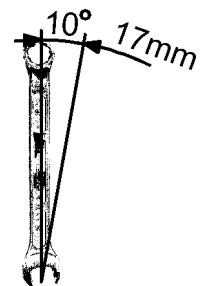

FIGURE 2

REP 3.24 Knife, continues

15. If the set is not correctly cut in the middle, loosen the four mounting screws (11) in the middle and keep the mounting screws tightened at the ends.
Turn the adjustment screw (10) in the middle 1/36 revolution or 10°. See figure 2.
Repeat step 8 and 9, then return to this step until it cuts the set all clean on 20 folded sheets.

NOTE: *As guidance you can trim a 25 sheet set to clearer see if the result of the adjustments are correct.*

16. If the set is not correctly cut on one of the ends after step 15, loosen the adjustment screw (10) in the middle and start over from step 12.
17. Tighten the lock nuts (9).
18. Return the machine to operational condition.

CAUTION: *If the knife/knives has been damaged, they have to be replaced or sharpened even if a correct result is obtained because of shortened life time.*

NOTE: *When the upper knife becomes dull it is possible to sharpen it.
The upper knife can be sharpened until it is 70 mm wide at the shorter end.*



REP 3.25 Infeed shaft

If this action is due to old or broken o-rings, skip item 9-10.

If removing drive shaft sprocket is intended, do this before removing E-clip.

REMOVAL

1. Switch off main power switch and remove power cord.
2. Remove front and rear cover according to REP 3.1 and 3.2
3. Remove transmission chain (1) according to REP 3.28.
4. Remove springs (2) from infeed linkage (3) on both sides.
5. Remove screws holding compressing shaft (4) to infeed linkage.
6. Move all o-rings to front end of shafts and lift out compressing shaft.
7. Remove rear E-clip on drive shaft (5) and push shaft into bearing in rear side frame.
8. Remove o-rings from drive shaft.
9. Remove sprocket (6) from drive shaft and remove infeed linkage and washers.
10. Push/Pull rear bearing out of side frame and lift out shaft.

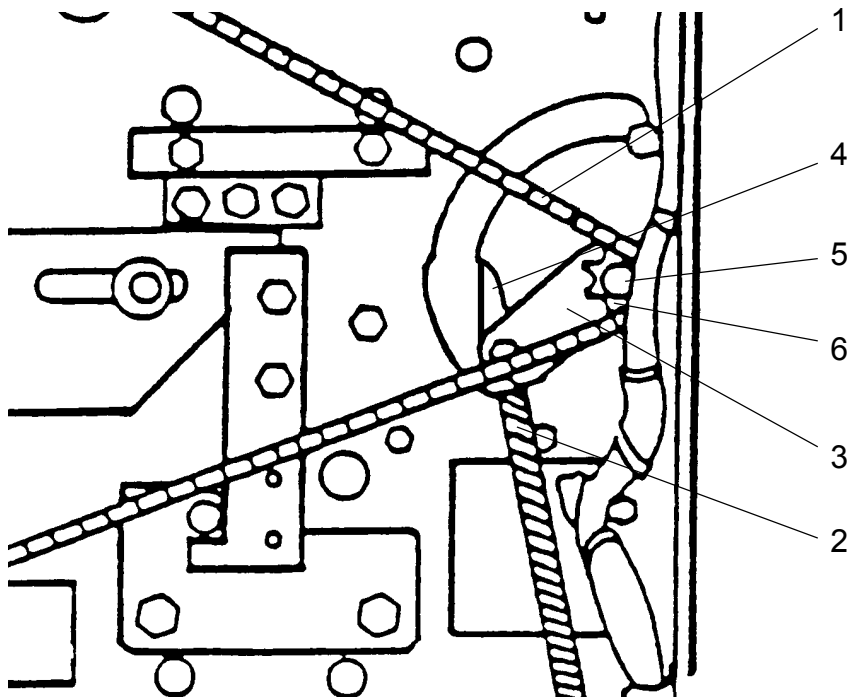

INSTALLATION/ADJUSTMENT

PURPOSE

The purpose is to ensure that the compressing shaft is aligned with paper path.

INSTALLATION

1. Fit shaft and rear bearing into side frame and fit o-rings on shafts.
2. Mount E-clip, washers, infeed linkage and sprocket on drive shaft.
3. Mount infeed linkage on compressing shaft, make sure that shaft is aligned with paper path and tighten locknuts on screws.
4. Fit springs on screws and mount transmission chain.

REP 3.26 Lower outfeed belts

REMOVAL

1. Switch the TR85 to A3 (11"X17") position.
2. Switch off the main power switch and disconnect the power cord.
3. Remove lower cover, outfeed side according to REP 3.4.
4. Open top cover and remove deck plate according to REP 3.6.
5. Remove transmission chain from lower out feed shaft according to REP 3.28.
6. Remove E-clip at rear side frame bearing on out feed shaft.
7. Loosen the two screws (1) holding the adjustable out feed shaft (2) to knife beam brackets(3).
8. Push/pull out feed shaft out of bearing in front side frame.
9. Remove one of the screws holding the adjustable shaft and remove the lower out feed belts (4).

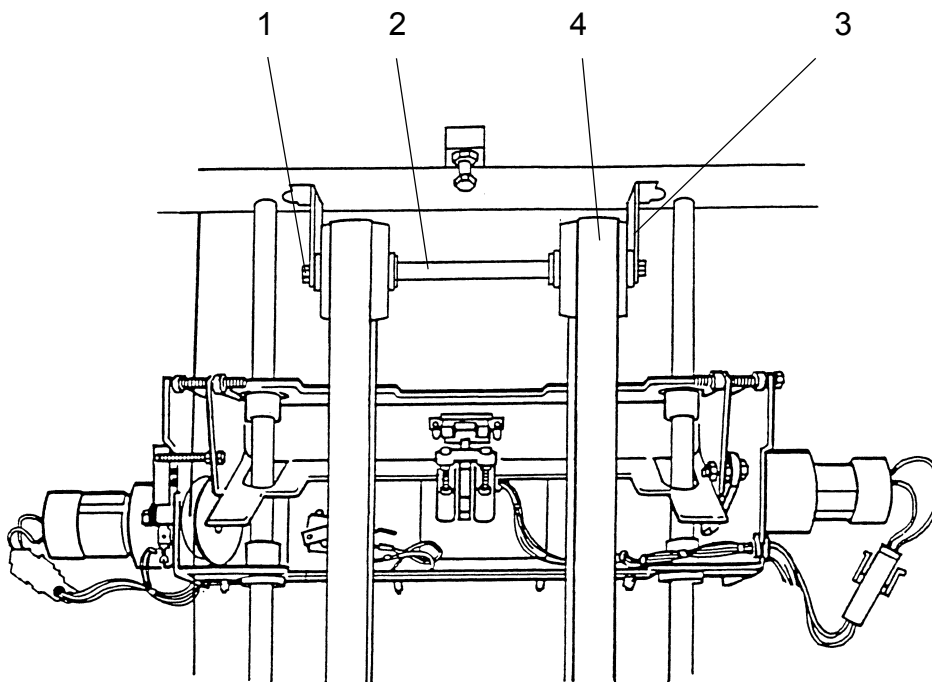

INSTALLATION/ADJUSTMENT

PURPOSE

The purpose is to ensure correct out feed by equal tension of the out feed belts.

INSTALLATION

1. Fit belts on rollers.
2. Fit out feed shaft into bearing and mount E-clip and transmission chain.
3. Fit belts on rollers, tension belts and tighten screws on adjustable shaft.
4. Mount deck plate and lower out feed cover.

CAUTION: Avoid damaging the support rollers on deck plate when removed.

REP 3.27 Upper outfeed belts

REMOVAL

1. Switch off the main power switch and disconnect the power cord.
2. Remove belt stacker and remove front and rear cover according to REP 3.1 and 3.2.
3. Remove springs (7) and six of the screws holding upper out feed cover (top pair remains).
4. Open top cover and tilt upper out feed cover according to fig. 1.
5. Remove E-clip, spring bracket (1), plastic washers and needle bearings (2) from compressing shaft.
6. Remove E-clips (6) at outer compressing brackets and push/pull out shaft.
7. Remove transmission chain from sprocket on upper out feed shaft according to REP 3.32.
8. Remove E-clips next to bearing 839 in side frames and pull bearings out of side frame.
9. Remove out feed compressing assy.
10. Loosen the two screws (4) and remove the upper feed belts (5).

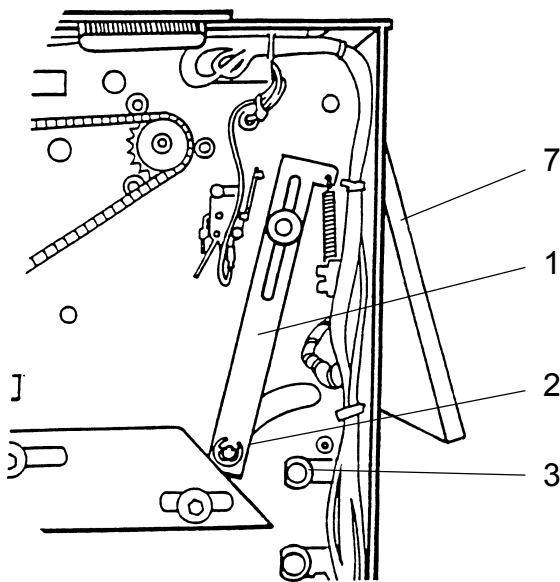

FIGURE 1

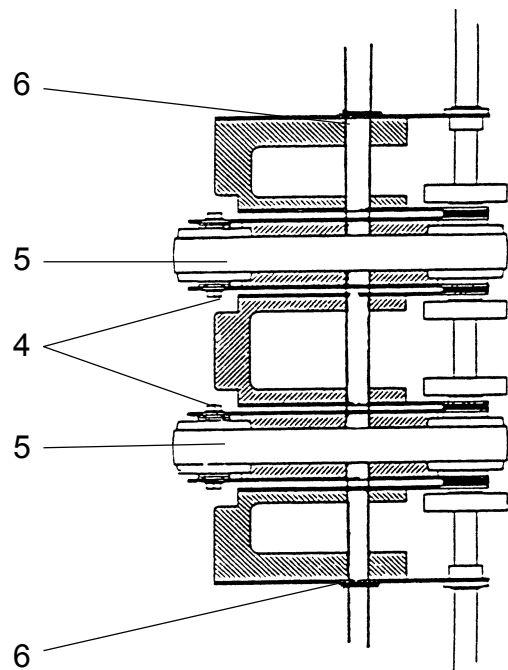

FIGURE 2

INSTALLATION/ADJUSTMENT

PURPOSE

The purpose is to ensure correct out feed by equal tension of the out feed belts.

INSTALLATION

1. Tension the out feed belts and tighten the screws.
2. Insert compressing assy into TR85, fit bearings into side frames and continue in reversed order compared to removal.

CAUTION: Avoid damaging the support rollers on deck plate when mounting compressing assy.

REP 3.28 Transmission chain

REMOVAL

1. Switch off the main power and remove the power cord.
2. Remove front cover according to REP 3.1.
3. Lift off chain tensioner (1) from transmission chain (2).
4. Lift off chain from sprocket on upper out feed shaft.
5. Lift off chain from sprocket on lower out feed shaft.
6. Remove chain.

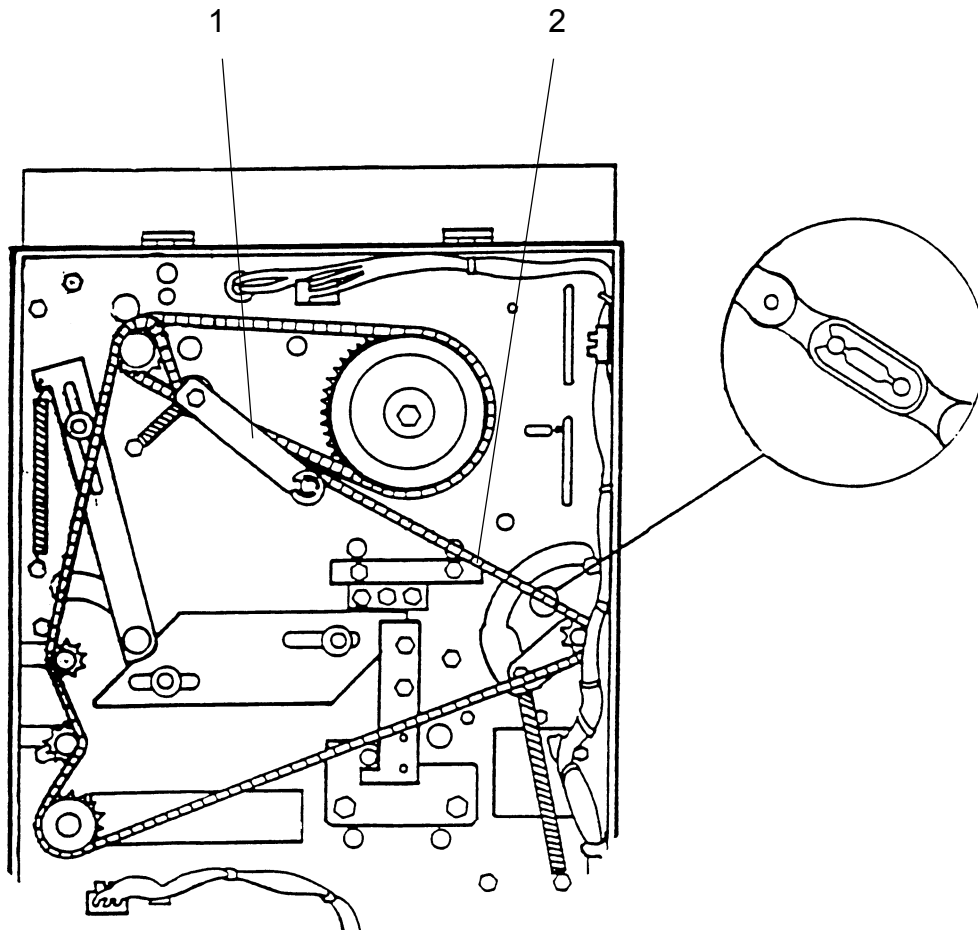

INSTALLATION/ADJUSTMENT

INSTALLATION

Install chain as in figure.

CAUTION: Make sure that chain lock is in right direction.

REP 3.29 Knife support chain

REMOVAL

1. Switch off the main power switch and remove the power cord.
2. Remove front cover according to REP 3.1.
3. Remove transmission chain according to REP 3.28.
4. Remove chain tension spring (1) and flip tensioner (2) over to crank shaft sprocket (3).
5. Loosen the three screws (4) holding MOT 2 1-2 turns and push the motor towards the crankshaft.
6. Lift the knife support chain off the motor sprocket and remove chain.

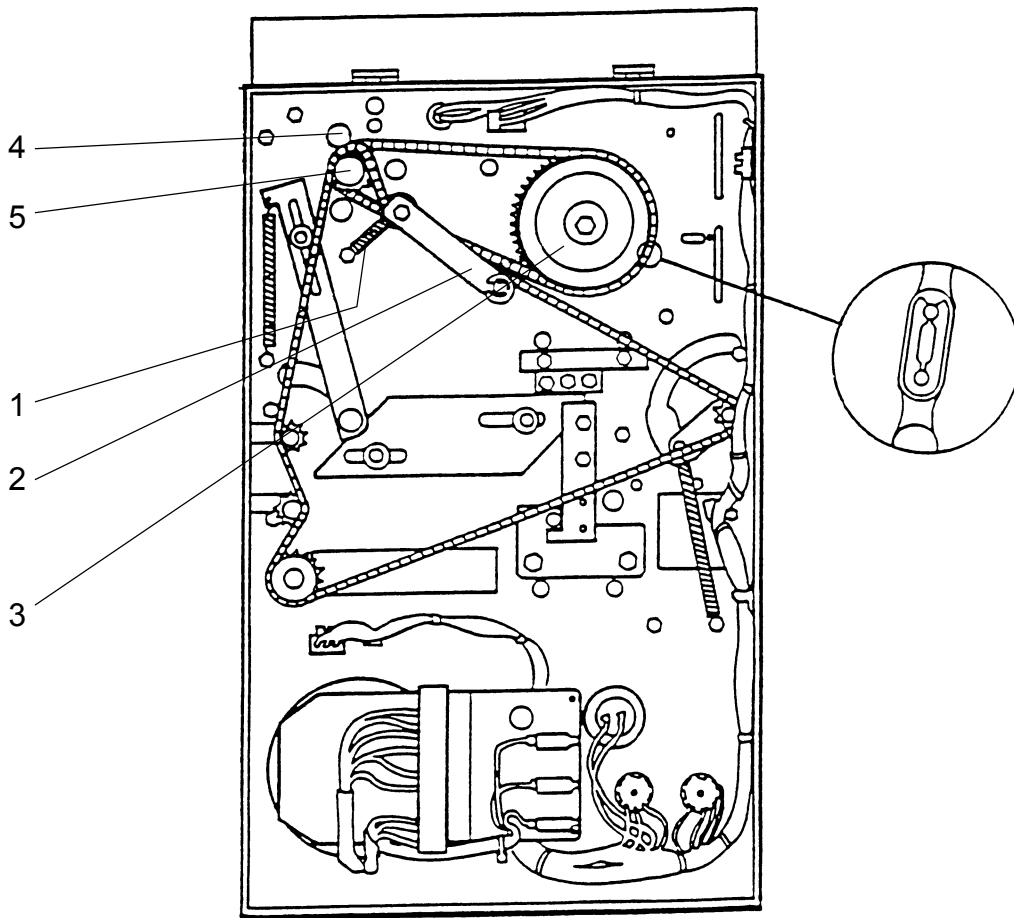

INSTALLATION/ADJUSTMENT

INSTALLATION

1. Mount knife support chain on to crankshaft sprocket.
2. Mount chain on motor sprocket.
3. Tension the chain by moving the motor and tightening the screws.
4. Mount transmission chain according to REP 3.28.

CAUTION: Make sure that chain locks is in right direction. There should be no slack in chain.

REP 3.30 Knife chain

REMOVAL

WARNING: Remove the safety block (1) from the interlock bypass bracket and place it between the knife beams, or rotate the upper knife beam to the down position, to prevent knife from falling.

1. Switch off the main power switch and remove the power cord.
2. Remove rear cover according to REP 3.2.
3. Disconnect front panel extension from front panel (2).
4. Loosen the three screws (3) holding knife motor 1-2 turns, and push motor towards the crankshaft.
5. Lift the knife chain off the motor sprocket (4) and remove chain.

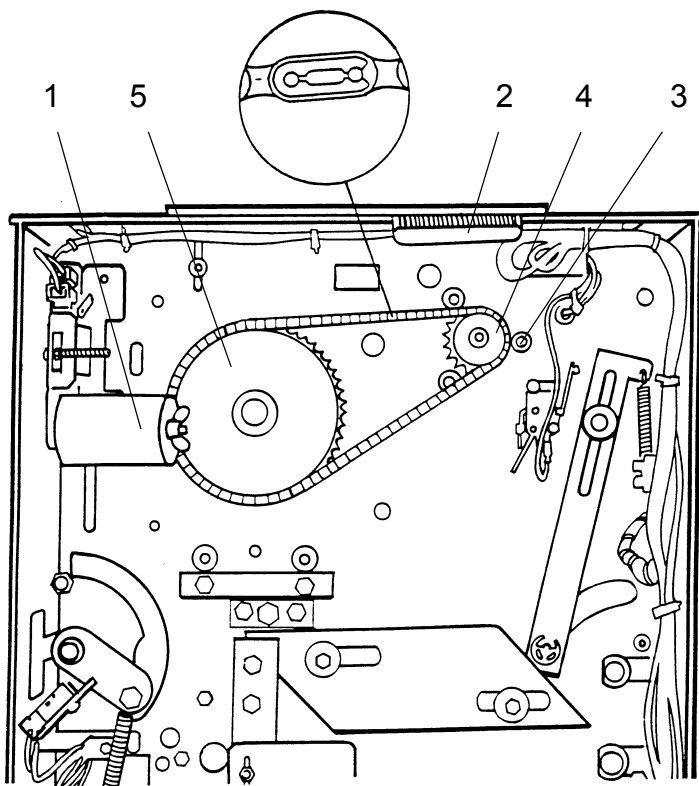

INSTALLATION/ADJUSTMENT

INSTALLATION

1. Mount knife chain on to crankshaft sprocket (5).
2. Mount chain on motor sprocket.
3. Tension the chain by moving the motor and tightening the screws.
4. Remove safety block from knife beams and place it on the bypass bracket.

CAUTION: Make sure that the chain locks in its right direction. There should be no slack in chain.

EDI 4.1 Test points

The test points can be used to verify components function.
 Any common ground can be used as a negative connection.
 Test points 1-6 are numbered from left to right.

		Not activated	Activated
TP1	Turning of stop carriage (SOS on PCB)	14-15 VDC	<2 VDC
TP2	Exit sensor signal from SR85	>14 VDC	
TP3	Signal from start sensor SOS 10	>14 VDC	<1VDC
TP4	Out feed sensor LED1/PT1	>9 VDC	
TP5	End position for stop carriage (SOS on PCB)	14-15 VDC	<2VDC
TP6	Scrap bin sensor PR1 (Adjust on trimmer)	8.5-10 VDC	
TP7	Knife home position sensor (SOS on PCB)	14-15 VDC	<2VDC
TP8	Start of transmission motor (SOS on PCB)	14-15 VDC	<2VDC
TP9	11"/A4 sensor (SOS on PCB)	14-15 VDC	<2VDC
TP10	14" sensor (SOS on PCB)	14-15 VDC	<2VDC
TP11	17"/A3 sensor (SOS on PCB)	14-15 VDC	<2VDC

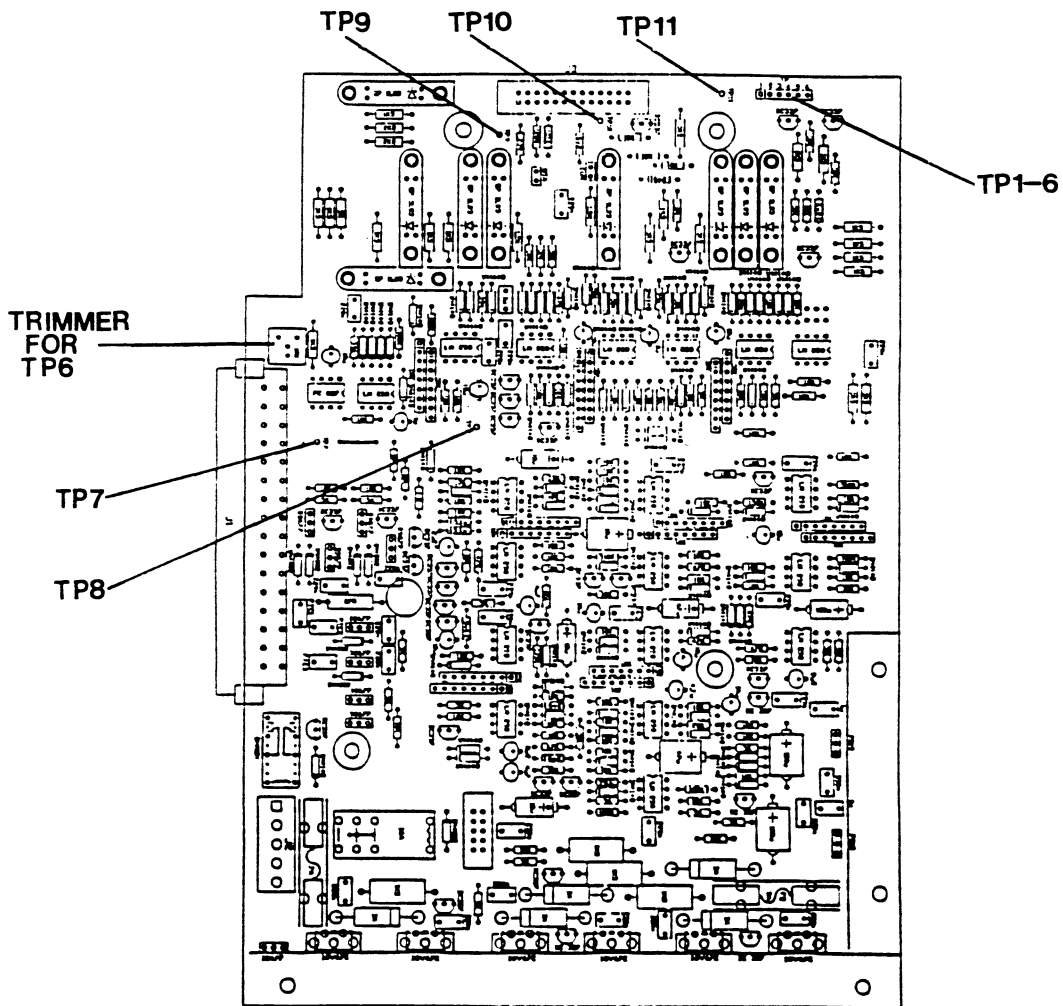

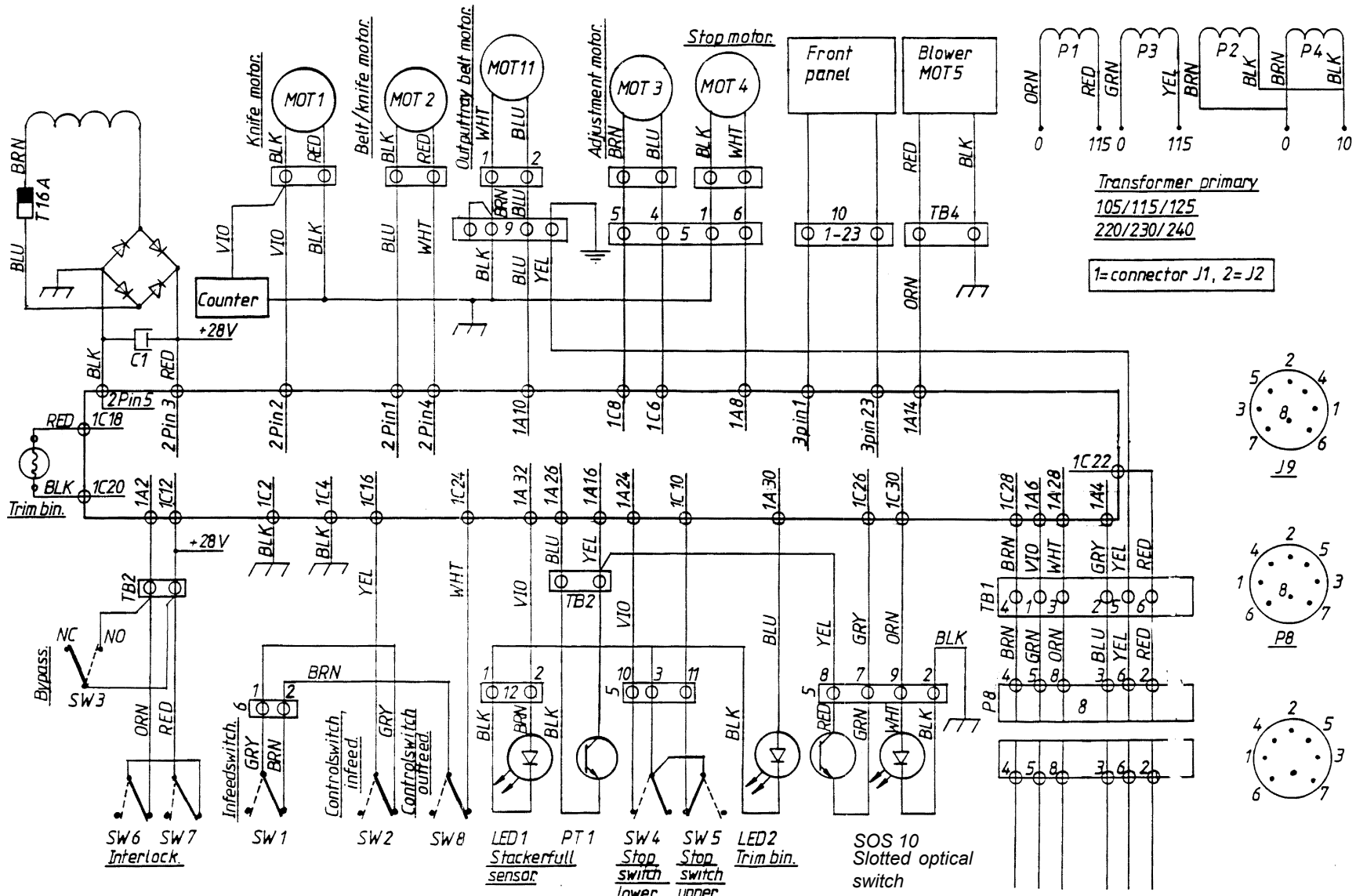

1=connector J1, 2=J2

Transformer primary
105/115/125
220/230/240

Switches in home position, trimmer mode.

Det.nr (Ant.)	Benämning			Material	Mod.nr Amne Dimension	Anm.
Konstr.	Ritad	Kontr.	Godk.	Stand.	Skala	Rev.dat.
PLOCKMATIC International AB					WIRING DIAGRAM TR85	
					EDI 4.2	
					Art.nr.	Dat. 000825
					Ritn.nr.	3-8950

EDI 4.3 Electrical components list

MOT 1	Knife motor	PAGE 4.4.3
MOT 2	Transmission motor	PAGE 4.4.3
MOT 3	Adjustment motor	PAGE 4.4.1
MOT 4	Trimmer stop motor	PAGE 4.4.1
MOT 5	Blower motor	
SW 1	Infeed switch	PAGE 4.4.1
SW 2	Control switch infeed, upper shaft	PAGE 4.4.2
SW 3	Bypass switch	PAGE 4.4.2
SW 4	Stop carriage switch, lower position	PAGE 4.4.1
SW 5	Stop carriage switch, upper position	PAGE 4.4.1
SW 6&7	Interlock switch	PAGE 4.4.3
SW 8	Control switch, outfeed	PAGE 4.4.2
SOS 10	Slotted optical switch	PAGE 4.4.1
LED 1	Outfeed LED	PAGE 4.4.3
PT 1	Outfeed photo transmittor	PAGE 4.4.3
LED 2	Scrap paper bin LED	PAGE 4.4.1
PR 1	Scrap paper bin sensor	PAGE 4.4.2

VIEW OF STOP CARRIAGE

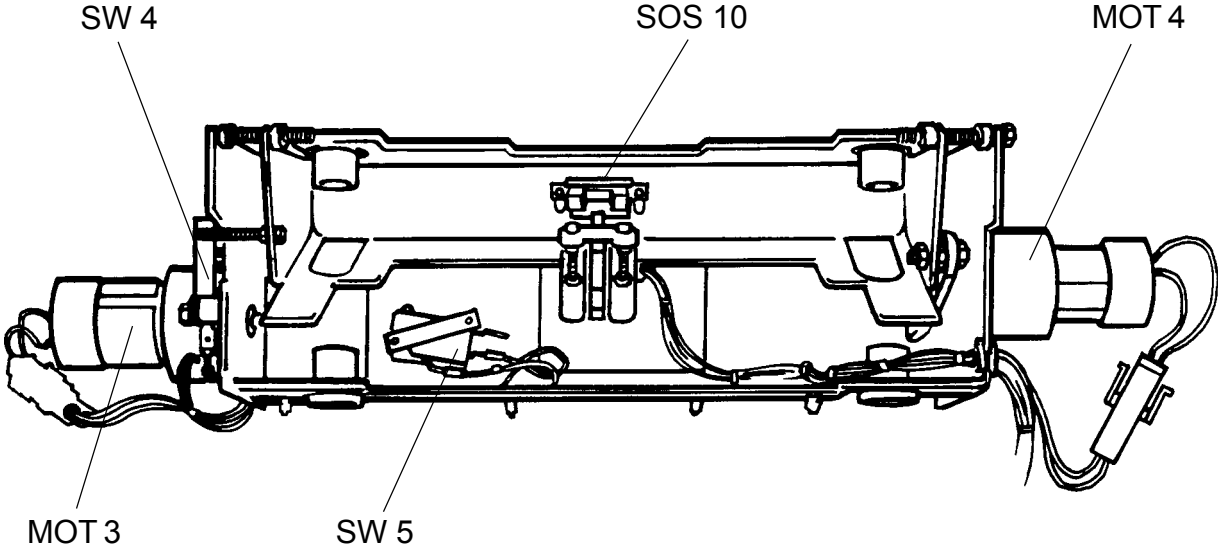

VIEW OF INFEED SIDE

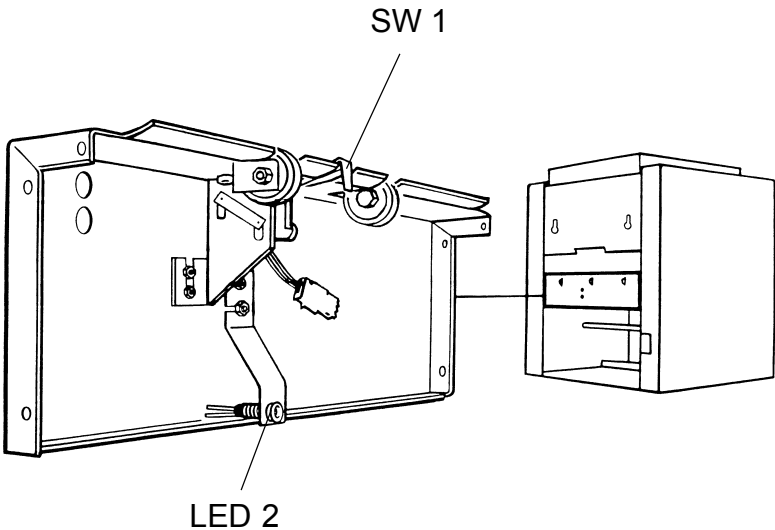

VIEW FROM RIGHT BEHIND THE SCRAP PAPER BIN

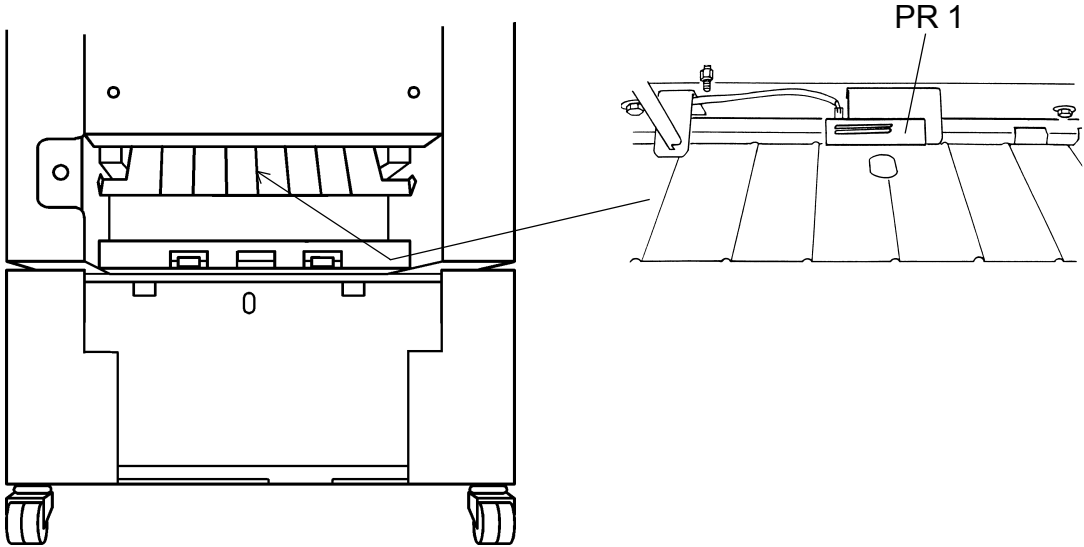

REAR VIEW

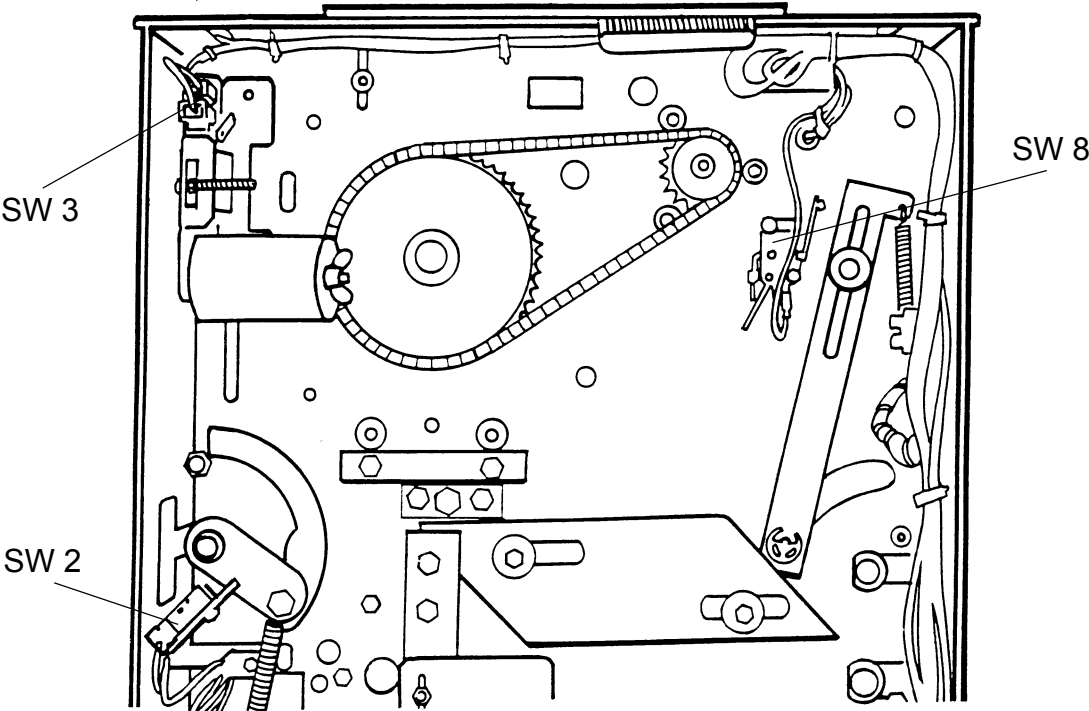

EDI 4.4 Electrical components location

RIGHT VIEW

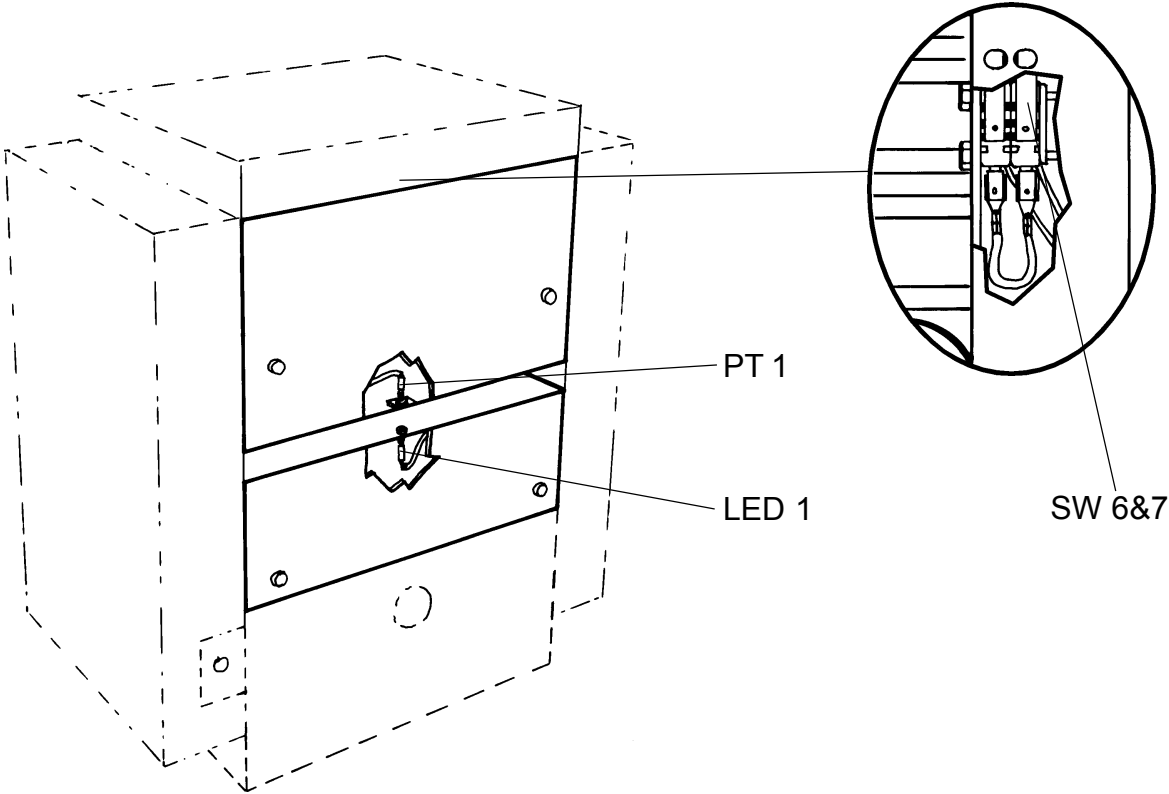

TOP VIEW

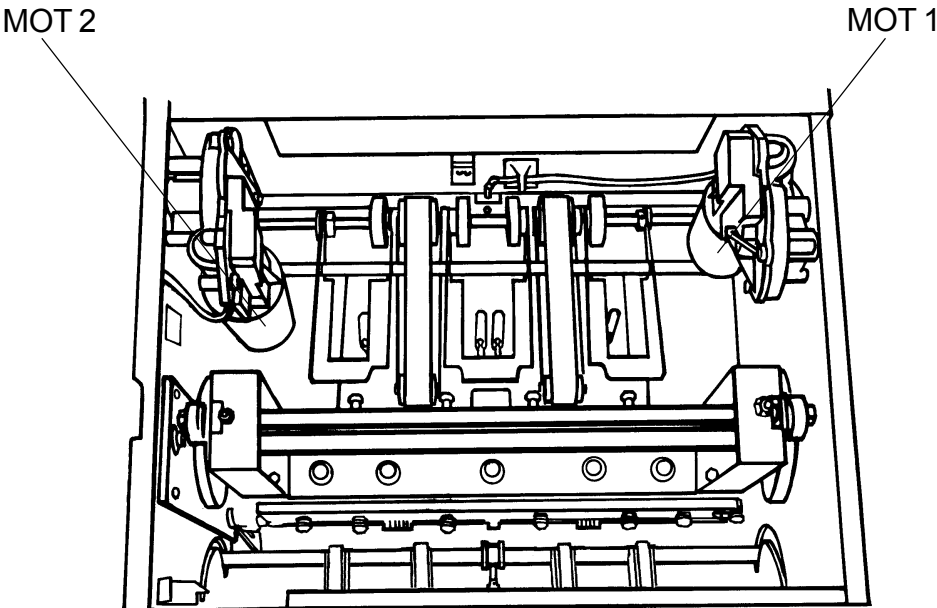

FIP 5.1 Fault isolating procedure

GUIDELINES

The fault isolating procedure is showing the operating sequence of the trimmer from switching on for a specific job to stacking of sets as a reference.

Follow the below guide to systematically locate information in the fault isolating procedure.

SEQUENCE OF OPERATION -Were in the operating sequence does the problem occur?

OBSERVED FAULT -What is the observed fault?

POSSIBLE CAUSE -What are the possible causes for the problem to occur?

FAULT ISOLATION/REPAIR -Guidelines and reference for corrective actions.

FIP 5.1 Fault isolating procedure

SEQUENCE OF OPERATION	OBSERVED FAULT	POSSIBLE CAUSE	FAULT/ISOLATING REPAIR	
Trimmer switched on.	No machine initialisation.	Secondary fuse in trimmer.	Located at the transformer	
		24 VDC supply to PCB 89-1.	Check for 30 VDC at connector J1 pin C12 and common ground on PCB 89-1.	
		Primary circuit from stapler folder 220/115 Volts.	Check voltage at power cord from stapler folder.	
		Main PCB defective.	Replace PCB 89-1 see REP 3.8.	
	Belts running continuously.	Phototransistor/LED in stapler folder defective.	Start signal circuit stapler folder to trimmer interrupted.	Check connection of interface cable.
			Main PCB defective.	Replace PCB 89-1 see REP 3.8.
		Trimmer knife cycling continuously.	Knife position indicator misadjusted.	Adjust according to REP 3.8.
	Knife home position sensor defective.		Check test point TP7 see EDI 3.31.	
	Jam indication printer.	Main PCB defective.	Replace PCB 89-1 see REP 3.8.	
			Interlock switches on top cover defective.	Replace/adjust SW6, SW7 see REP 3.18.
		Interface cable not connected.	Connect interface cable.	

FIP 5.1 Fault isolating procedure

SEQUENCE OF OPERATION	OBSERVED FAULT	POSSIBLE CAUSE	FAULT/ISOLATING REPAIR
Set up procedure.	Format setting inoperative.	PTC resistor on main PCB activated (stop carriage has to activate and reverse from end switch in two seconds).	Switch off stapler folder for five seconds M/C will regain operative mode when switched on.
		Insufficient connection on stop carriage.	Check connection of stop carriage.
		Slotted optical switches on PCB defective.	Check test points TP5,9,10 and 11 see EDI 3.31.
		Stop carriage motor MOT 3 defective.	Check for app. 24 VDC at J1 pin C8 and J1 pin C6.
		Main PCB defective.	Replace PCB 89-1 see REP 3.8.
Paper transport in stapler folder.	Jam indication trimmer.	Control switch SW2 defective/misadjusted.	Check according to REP 3.15.
		Compressing brackets remaining in upper jam/clearance position.	Check compressing brackets.
		Control switch compressing brackets SW8 defective/misadjusted.	Check according to REP 3.19.
		Infeed switch SW1 defective/misadjusted.	Check according to REP 3.14.

FIP 5.1 Fault isolating procedure

SEQUENCE OF OPERATION	OBSERVED FAULT	POSSIBLE CAUSE	FAULT/ISOLATING REPAIR
Paper transport in stapler folder cont.	Scrap paper bin full indication.	Scrap paper bin full.	Empty scrap paper bin.
		LED2/PR1 defective/misadjusted.	Check voltage on PR1 see REP 3.22.
		Main PCB defective.	Replace PCB 89-1 see REP 3.8.
Infeed trimmer.	Belt, transport not running.	Photo transistor, outfeed stapler folder defective.	Check voltage on test point TP2 see EDI 3.31.
		Transmission motor MOT2 defective.	Check for 24 VDC on motor MOT2.
		Main PCB defective.	Check for 24 VDC on connector J2 pin 1 and 2 see EDI 3.32.
		Transmission defective.	Check for loose hardware.
Set entering belt transport.	Skew cutting.	Incorrect belt tension.	See REP 3.26 and 3.27 for adjustment.
		Position of cut varying.	See REP 3.26 and 3.27 for adjustment.
	Incorrect position of cut.	Incorrect position of stop carriage switches.	See REP 3.16 and 3.17 for adjustment.
		Mechanical obstacles.	Grease, oil, burrs etc. on paper path.
		Incorrect position of stop carriage indicator.	Adjust indicator on stop carriage so that the cutting margin is 4-5mm.
	Slotted optical switches defective.	Check test points TP9-11 see EDI 3.31.	

FIP5.1 Fault isolating procedure

SEQUENCE OF OPERATION	OBSERVED FAULT	POSSIBLE CAUSE	FAULT/ISOLATING REPAIR
Set entering belt transport cont.	Incorrect position of cut cont.	Main PCB defective.	Replace PCB 89-1 see REP 3.8.
Set arrives at the trimmer stop.	Trimmer stop not in upper position.	Off-line mode selected on front panel.	Select trimme mode.
		Stop carriage switch SW5 defective.	See REP 3.17 for repair.
		Trimmer stop motor MOT4 defective.	Check for DC voltage on connector J1 pin 8A and common ground on PCB 89-1. See REP 3.13 for repair.
		Main PCB defective.	Replace PCB 89-1 see REP 3.8.
	Set does not activate start switch SOS10.	Low drive on infeed belts.	Clean/tension infeed belts.
		Mecanical obstacles.	Grease, oil, burrs etc. on paper path.
		Switch actuator misadjusted.	Adjust according to REP 3.20.
No knife operation despite switch actuation.	SOS10 defective.	Check/replace according to REP 3.20.	
	Main PCB defective.	Check for 24 VDC at connector J2 pin 2 and common ground on PCB 89-1 / replace PCB 89-1 see REP 3.8.	
	Knife motor MOT1 defective.	Check for 24 VDC at motor / replace according to REP 3.10.	

FIP 5.1 Fault isolating procedure

SEQUENCE OF OPERATION	OBSERVED FAULT	POSSIBLE CAUSE	FAULT/ISOLATING REPAIR
Set arrives at trimmer stop cont.	Jam indication and direct outfeed of the sets.	Infeed switch SW1 misadjusted/defective.	Check/adjust according to REP 3.14.
		Mechanical obstacles in paper transport.	Time from actuating SW1 to start switch SOS10 to long, see previous section "set entering belt transport".
		Start switch SOS10 defective.	Check replace according to REP 3.20.
		Main PCB defective.	Replace PCB89-1 see REP 3.8.
Stop, transport belts.	Belts does not stop.	Voltage on outfeed phototransistor PL8 to low.	Check voltage on test point 2 see EDI 3.31.
		Stop signal to MOT 2 interrupted.	Replace PCB 89-1 see REP 3.8.
Knife, stroke down.	Marks on sheets. Trimmer stop remaining in upper position.	Feeding belts dirty.	Clean feeding belts.
		Loose connectors on stop carriage.	Check connectors.
		Stop carriage switch, lower position SW4 defective/misadjusted.	Check/replace SW 4 according to REP 3.16.
		Trimmer stop motor MOT4 defective.	Check for 24 VDC on connector J1 pin 8A and common ground on PCB 89-1.
		Main PCB defective.	Replace PCB 89-1 see REP 3.8.

FIP 5.1 Fault isolating procedure

SEQUENCE OF OPERATION	OBSERVED FAULT	POSSIBLE CAUSE	FAULT/ISOLATING REPAIR
Cutting.	Knife jams.	Set to thick.	More than specified maximum Qty of sheets.
		Loose hardware.	Check sprockets for knife action.
		Dull knife.	Sharpen/replace knives See REP 3.24.
	Degraded cutting performance.	Dull knives.	Sharpen/replace knives.See REP 3.24.
		Knives misadjusted.	Check adjustments of knives.See REP 3.24.
Cutting stroke upwards.	Knife does not stop, double action.	Knife positione indicator misadjusted.	See REP 3.8 for adjustment.
Outfeed.	Transport belts does not start.	Time out, dull knife indication on front panel.	See previous section "cutting".
	Trimmer stop does not reach upper position.	Stop carriage switch SW5 upper position,defected/misadjusted.	Check replace SW5 according to REP 3.17.
		Main PCB defective.	Replace PCB 89-1 see REP 3.8.
	Sets coming out skew on belt stacker.	Not enough friction on feed belts.	Clean/tension feed belts.

FIP 5.1 Fault isolating procedure

SEQUENCE OF OPERATION	OBSERVED FAULT	POSSIBLE CAUSE	FAULT/ISOLATING REPAIR
Belt stacker operation.	Conveyor belt does not run.	Belt stacker not connected. Outfeed sensor defective/misadjusted. (jam indication on front panel) Belt stacker motor defective. Main PCB defective.	Connect beltstacker / check connector. Check voltage at TP4 see EDI 3.31. Check for 24 VDC at belt stacker motor. Check for 24 VDC at connector J1 pin A10 and common ground on PCB 89-1.

MAI 6.1 Preventive Maintenance

Note: All INSTRUCTIONS are referring to the Trimmer TR 85 Service Manual.
The REFERENCE column is referring to the Spare parts list of Model TR85.

CHECK POINT	INSTRUCTION	REFERENCE	250000	500000
All machine, Paper paths etc.	Use a vacuum cleaner, towels and brushes to clean the machine from paper dust. Use an alcohol to clean from ink.		Clean	Clean
Interlock switch (SW6 & 7)	Check the function of the switches, adjust according to REP 3.19. Make sure that both switches is activated when the Lid is closed.		Check	Check
Infeed switch (SW1)	Check the function of the switch, adjust according to REP 3.15	Page 1.9 Item 3	Check	Check
Control switch in feed, upper shaft (SW2)	Check function of the switch, check adjustment according to REP 3.16.	Page 1.5 Item 7	Check	Check
Infeed belts (4 pcs)	Use a rubber reactivator alcohol fluid to clean the infeed belts. Check for wear, if worn replace.	Page 1.13 Item 3	Clean	Clean
Transmission chain	Apply grease between idler wheel and shaft. Check for wear, if worn replace. Replace every 1000 000.	Page 1.7 Item 12	Oil	Oil
Trnsmission chain tensioner	Apply grease between idler wheel and shaft. Check for wear, if worn replace. Check adj. according to REP 3.32. Replace every 1000 000.	Page 1.7 Item 24	Grease/ Check	Grease/ Check
Knife chian (1 pce) / Knife support chain (1 pce)	Apply chain oil. Check for wear, if worn replace. Replace every 1000 000.	Page 1.5 & 1.7 Item 15 & 20	Oil	Oil
Scrap bin full sensor / LED	Use compressed air to clean the sensor and LED. Adjust according to REP 3.23.	Page 1.9&1.21 Item 2&14	Clean	Clean

MAI 6.1 Preventive Maintenance, continues

CHECK POINT	INSTRUCTION	REFERENCE	125000	250000
Upper transport belt (2pcs)	Use a rubber reactivator alcohol fluid to clean the transport belts. Check the tension of the belts, adjust by loosen the two screws holding the big idler wheel (the idler wheel closest to the knife), stretch the belt and tighten the screws. Check for wear if worn replace.	Page 1.15 Item 7	Clean	Clean
Lower transport belt (2pcs)	Use a rubber reactivator alcohol fluid to clean the transport belts. Check for wear, if worn replace. frame.	Page 1.17 Item 5	Clean	Clean
Slotted optical switch (SOS 10)	Use compressed air to clean the sensor. Adjust the sensor according to REP 3.21.	Page 1.21 Item 4	Clean	Clean
Low position microswitch (SW4)	Check function of the switch, adjust according to REP 3.17.	Page 1.21 Item 8	Check	Check
Top position microswitch (SW5)	Check function of the switch, adjust according to REP 3.18.	Page 1.21 Item 9	Check	Check
Gear rack	Apply grease on format adjustment gear rack and on the gear.	Page 1.21 Item 19&20	Grease	Grease
Outfeed sensor & LED (PT1 & LED 1)	Use compressed air to clean the sensor and the LED. Adjust according to REP 3.22.	Page 1.11 Item 4&5	Clean	Clean
FINAL CHECK POINTS				
Trimming result check	Run a 22 sheets booklet of 80-gsm paper to check the trimming result. If the trimming result is poor, replace the knives.		Check	Check/ Replace